

GEMÜ® 1436 cPos

Intelligent Positioner and integrated Process Controller

GB OPERATING INSTRUCTIONS



Status 03.11.16
From version 2.0.3.3

Quick commissioning of the GEMÜ 1436 cPos:

Prerequisites:

- Mounted to the valve.
- Air supply, max. 7bar, connected.
- 24 V DC supply voltage connected.
- Set value and actual value signals need not be connected.
- For correct commissioning proceed as described in the following flow chart:

Automatic fast initialisation

i The initialisation can alternatively be started via the parameter "Init Valve".

Switching message after connecting the supply voltage. without factory setting

NoInit XX.X%

 Valve can be opened and closed

This message is displayed for five seconds and then deleted automatically. It can be switched off within the five seconds by pressing the  key.

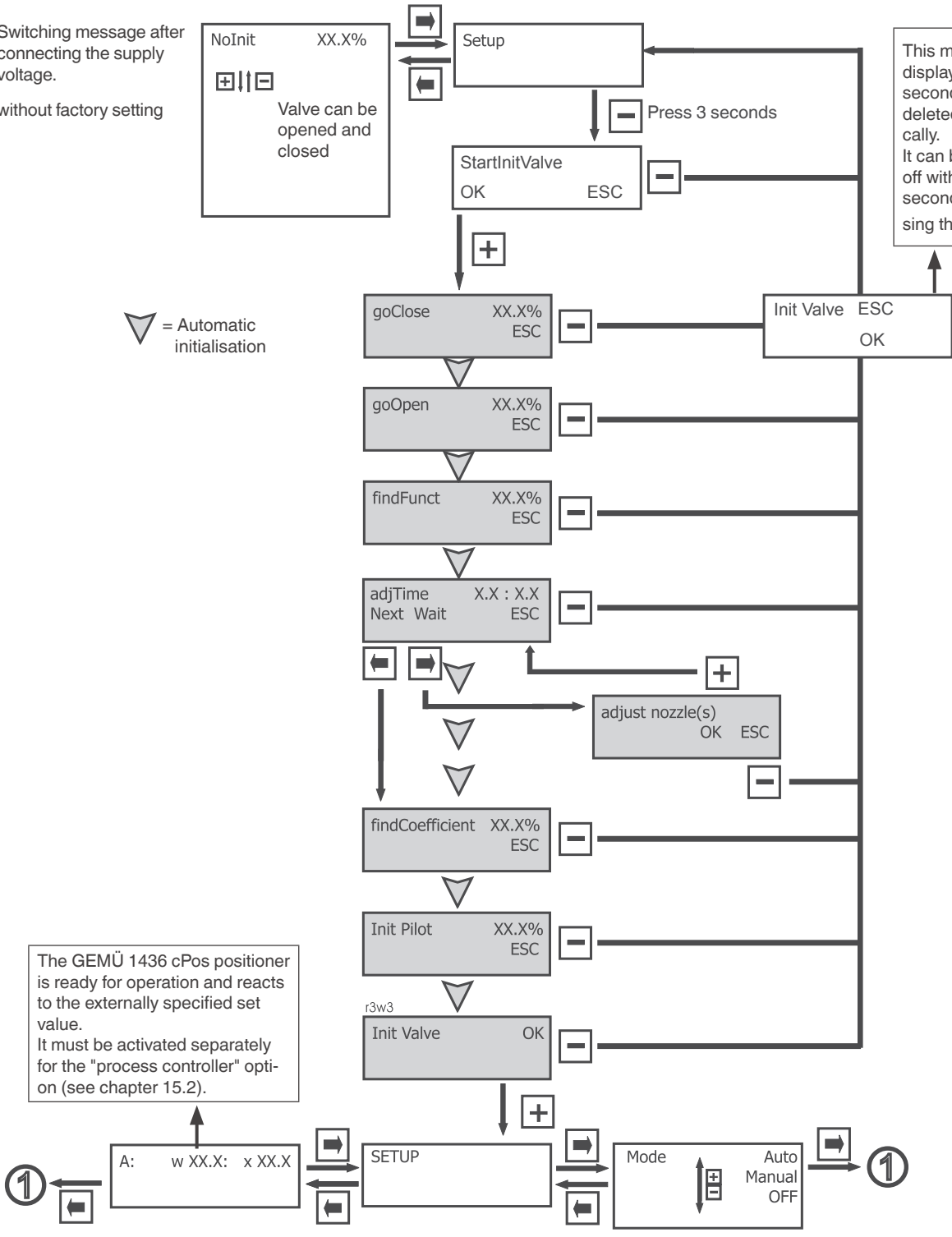
 = Automatic initialisation



The GEMÜ 1436 cPos positioner is ready for operation and reacts to the externally specified set value. It must be activated separately for the "process controller" option (see chapter 15.2).

Contents

1	General safety information	4	11	Configuration menu (Setup)	20
1.1	General information	4	11.1	Changes in the configuration menu	20
1.2	Explanation of symbols and signs	4	11.2	Access authorisation in the configuration menu	20
1.3	Safety notes	4	11.3	Menu structure 1 Service	21
1.4	Correct use	5	11.4	Menu structure 2 SetBasics	22
1.5	Information on use in damp conditions	5	11.5	Menu structure 3 SetFunction	23
1.6	Mounting position	5	11.6	Menu structure 4 SetCalibration	24
1.7	Tools required for installation and assembly	5	11.7	Menu structure 5 Communication	25
2	Manufacturer's information	5	12	Parameter table	26
2.1	Transport	5	13	Explanation of parameters	30
2.2	Delivery and performance	5	13.1	1 Service	30
2.3	Storage	5	13.1.1	Scanning the input and output signals	30
2.4	Function	5	13.1.2	Activating or deactivating the user access	31
2.5	Fail safe function	5	13.1.3	Reading out, deleting and deactivating error messages	32
3	Diagrammatic view of the inputs and outputs	6	13.1.4	Display serial number, software version and ID and enter TAG no.	32
4	Mechanical mounting	7			
4.1	Mounting to linear actuators	7	13.2	2 SetBasics	33
4.1.1	Preparation of the valve actuator	7	13.2.1	Definition of actual value and set value inputs	33
4.1.2	Assembling the travel sensor	7	13.2.2	Reset	33
4.1.3	Mounting the positioner	7	13.2.3	Initialisation	33
4.1.4	Mounting the external travel sensor (only for version with remote mounting)	7	13.2.4	Making the display settings	33
4.2	Mounting to quarter turn actuators	8	13.3	3 SetFunction	34
4.2.1	Preparation of the valve actuator	8	13.3.1	Setting the process controller parameters (optional)	34
4.2.2	Assembling the travel sensor	8	13.3.2	Setting the positioner parameters	35
4.2.3	Mounting the positioner	9	13.3.3	Setting the dead zone	35
4.2.4	Mounting the external travel sensor (only for version with remote mounting)	9	13.3.4	Setting the optional digital input parameters	35
4.2.5	Checking the mounted assembly	9	13.3.5	Setting output functions and switch points	36
4.3	Remote mounting to linear or quarter turn actuators	10	13.3.6	Setting the error time and error action	37
4.3.1	Preparation of the valve actuator	10	13.3.7	Storing parameter sets	37
4.3.2	Assembling the travel sensor	10	13.3.8	Defining the actual value output	37
4.3.3	Mounting the external travel sensor (only for version with remote mounting)	10	13.4	4 SetCalibration	38
4.3.4	Checking the mounted assembly	10	13.4.1	Determining the direction of actual value and set value	38
4.3.5	Mounting the mounting bracket	10	13.4.2	Defining the characteristics of the control curve	38
4.3.6	Connecting the travel sensor	10	13.4.3	Defining the direction of the travel sensor	39
5	Pneumatic connections	10	13.4.4	Defining the actual value output signal	39
6	Electrical connections	10	13.4.5	Determining switch points for error monitoring	39
6.1	Version with external actual value potentiometer (code S01)	11	13.4.6	Scaling the actual value and set value display	39
6.2	Supply voltage	11	13.5	5 Communication	40
6.3	Set value input (only effective for AUTO operating mode)	11	13.5.1	Setting the fieldbus parameters	40
6.4	Actual value input (sensor signal when operating as a process controller)	11	13.5.2	Setting the communication parameters	40
6.5	Actual value output	11	14	Error messages	41
6.6	Outputs	11	15	Quick guide	42
6.7	Digital inputs	11	15.1	Changing the set value signal and actual value signal	42
6.7.1	Use of actual value and set value inputs as digital inputs	12	15.2	Switching the process controller on or off (optional)	42
6.8	Digital inputs (optional)	12	15.3	Changing the control parameters (Proc P, Proc I, Proc D and Proc T)	43
6.9	RS232 – Interface	12	16	General information regarding control engineering	44
7	Operation	13	16.1	The control circuit	44
7.1	Operating and display elements	13	16.2	Control engineering terminology	44
7.2	Menu levels	13	16.3	Control parameters	44
7.2.1	Working level (Mode)	13	16.4	Adaptation of the controller to the controlled system	45
7.2.2	Configuration level (Setup)	13	16.5	Differential equation for the GEMÜ 1436 cPos	45
8	Changing parameters	13	16.6	Effects of the control parameters on the control system	45
9	Commissioning	14	16.7	Control characteristics and transitory responses	46
9.1	General information	14	17	Table for changes to the factory settings	47
9.2	Initial commissioning without factory setting (when supplied without a valve)	14	17.1	Changed control parameters	47
9.2.1	Automatic initialisation	14	17.2	Set values for the freely programmable characteristic curve	49
9.2.2	Manual initialisation	14	18	Disposal	49
9.2.3	Menu structure automatic and manual initialisation	15	19	Returns	49
9.2.4	Error messages during initialisation	16	20	Information	49
9.2.5	Initialisation parameters	17	21	Technical data	50
9.3	Initial commissioning with factory setting (positioner supplied mounted to the valve)	17	22	Order data	51
10	Operating modes	19	23	Fail safe function	61
10.1	Operating mode selection	19	24	Application examples	62
10.2	Automatic operation (A:)	19	24.1	GEMÜ 1436 cPos as process controller with 4-wire transmitter (GEMÜ 3021)	62
10.3	Manual operation (M:)	19	24.2	GEMÜ 1436 cPos s process controller with 2-wire transmitter (GEMÜ 3020)	62
10.4	Manual operation with flexible set value specification (F:)	19	25	EU Declaration of Conformity	63
10.5	Test mode (T:)	19		List of terms	64
10.6	Pause mode (OFF)	19			

1 General safety information

Please read the following notes carefully and observe them.

1.1 General information

Important requirements to ensure the perfect function of this GEMÜ 1436 cPos:

- Correct transport and storage
- Installation and commissioning by trained personnel
- Operation according to these operating instructions
- Recommended maintenance

The GEMÜ 1436 cPos must be used in accordance with these directions. All information in these operating instructions regarding operation, servicing and maintenance must be observed and applied. If the information is not observed, the operator's guarantee rights and the manufacturer's legal liability cease. The manufacturer shall undertake no responsibility for the GEMÜ 1436 cPos if these safety notes are not observed.

Therefore, you must observe:

- the contents of these operating instructions
- the relevant safety regulations for the installation and operation of electrical systems
- that this device must not be used in potentially explosive areas.

The regulations, standards and guidelines named in these operating instructions are only applicable in Germany. If the GEMÜ 1436 cPos is used in other countries, the local applicable regulations must be observed. When dealing with harmonised European norms, standards and guidelines, these apply within the Single European Market. The operator must also adhere to national rules and guidelines, if applicable. The descriptions and instructions in these operating instructions refer to the standard version.



All rights including copyright and industrial property rights are expressly reserved.

The safety information does not take into account:

- x Unexpected incidents and events, which may occur during installation, operation and servicing.
- x Local safety regulations which must be adhered to by the operator and by any additional installation personnel.

In cases of uncertainty:

- x Consult the nearest GEMÜ sales office.

1.2 Explanation of symbols and signs

Important information is identified in these operating instructions by the following symbols:



DANGER

This symbol indicates danger. There is **danger to life or health of persons** and/or **considerable material damage** can occur, if the instructions given here are not followed.



Slight bodily injury and damage to property can occur, if the **safety information** given in connection with this symbol is not observed.



This symbol indicates **notices** which give important information regarding your GEMÜ 1436 cPos.

1.3 Safety notes



DANGER

- Only qualified and trained personnel should assemble, electrically connect and commission the GEMÜ 1436 cPos. Use qualified personnel for operation, servicing, inspection and assembly. The areas of responsibility, the monitoring of personnel and their competence areas should be defined precisely by the operator. Train personnel with insufficient knowledge or, if necessary, have them trained by the manufacturer / supplier on order of the operator. Ensure that all members of personnel understand the safety instructions.
- Ensure that the power supply equipment is electrically safe.
- Ensure that the electrical values are correct.



DANGER

Exhaust air and cycle duties generate noise!

- Hearing damage.
- Wear hearing protection.

If the safety information is disregarded then persons, the environment and the GEMÜ 1436 cPos may be endangered. Furthermore, failure to observe the safety information may lead to a complete loss of claims rights.

Adhere to legal regulations.

1.4 Correct use

- X The GEMÜ 1436 cPos is suitable for use as defined in the data sheet. In order to ensure correct product function, the following notes should be observed. Pay attention to the information on the product labels.
- X Non-observance of these notes and the notes in the general operating instructions will lead to a loss of the guarantee on the GEMÜ 1436 cPos and of legal liability.
- X The GEMÜ 1436 cPos serves solely as a positioner and process controller and must be used according to the data sheet.
- X Any other use or use above and beyond this is not permitted. GEMÜ shall not be liable for any consequential damage which is solely at the user's risk.
- X Please pay attention to the pertinent technical safety regulations when planning both the use and operation of the device. The designer, plant constructor or operator is always responsible for positioning and mounting of the GEMÜ 1436 cPos.

1.5 Information on use in damp conditions



Under no circumstances whatsoever may the GEMÜ 1436 cPos be cleaned with a high pressure cleaning device because the protection class IP 65 is not sufficient for this.

The following information is intended to help when mounting and operating the GEMÜ 1436 cPos in damp conditions:

- Lay cables and pipework so that condensate or rain water that remains on the pipework / cables cannot enter the cable glands of the M12 plugs of the GEMÜ 1436 cPos.
- Check that all cable glands of the M12 plug and the fittings are mechanically secured.

1.6 Mounting position

The mounting position of the GEMÜ 1436 cPos is optional. When mounted upside down it must be ensured that no liquids or dirt can enter the outlet of the pressure relief valve.

1.7 Tools required for installation and assembly

The tools required for installation and assembly are not included in the scope of delivery.

2 Manufacturer's information

2.1 Transport

- Only transport the positioner by suitable means. Do not drop. Handle carefully.
- Dispose of packing material according to relevant local or national disposal regulations / environmental protection laws.

2.2 Delivery and performance

- Check that all parts are present and check for any damage immediately upon receipt.
- The scope of delivery is apparent from the dispatch documents and the design from the order number.
- The performance of the positioner is checked at the factory.
- If the GEMÜ 1436 cPos positioner is ordered as a complete unit with a valve, these parts and the accessories belonging to them are supplied ready assembled and factory set. The GEMÜ positioner is then ready for immediate operation.

2.3 Storage

- Store the positioner free from dust and moisture in its original packaging.
- Avoid UV rays and direct sunlight.
- Maximum storage temperature: 60 °C.

2.4 Function

The GEMÜ 1436 cPos is an intelligent electro-pneumatic positioner designed for mounting to pneumatic actuators. It can be operated as a positioner or a process controller depending on the design.

Normally the GEMÜ 1436 cPos is mounted directly to the actuator. The travel sensor is already integrated in the positioner (GEMÜ 1436 cPos can be optionally ordered with an M12 connector for remote mounting of the travel sensor). The travel sensor measures the current position of the valve and relays this position to the electronic control system of the GEMÜ 1436 cPos which correlates the actual value of the valve with the set value and adjusts the valve if necessary.

If the positioner is ordered with an additional process controller (optional), a current actual value signal (e.g. level, pressure, temperature, flow) is evaluated and the positioner adopts the function of a process controller.

The information required can be called-up on the two-line display of the GEMÜ 1436 cPos. Self-explanatory help texts that explain the meaning of the parameters called-up are also displayed.

The GEMÜ 1436 cPos is operated using four keys.

2.5 Fail safe function

The GEMÜ 1436 cPos has a fail safe function which ensures that the outlets are vented during a pneumatic and electrical power supply failure.

This fail safe function is not a substitute for specific plant safety requirements. The GEMÜ 1436 cPos is not a safety control system.

3 Diagrammatic view of the inputs and outputs

Additional functions of the positioner:

- Automatic initialisation
- Easy to understand help texts
- Limitation of opening and closing stroke
- Close tight function
- Selectable or settable characteristic curve
- Safety position "fail safe"
- Freely programmable alarm outputs
- among other things

PID process controller function:

- Freely adjustable parameters
- Set value setting via keypad or set value input

Operating parameters

Set value input for process or position control
0-20 mA 4-20 mA
Actual value input for process control
0-20 mA 4-20 mA
Actual value input for position control using the travel sensor
Digital inputs (optional) (Function programmable)
Supply voltage 24 V DC

Inputs



Actual value output
4-20 mA
Binary outputs
24 V DC
e. ^{SY} -com
Communication interface
Profibus DP / DeviceNet / Profinet

Outputs

Operation
Keypad

4 Mechanical mounting

4.1 Mounting to linear actuators

4.1.1 Preparation of the valve actuator

1. The actuator must be in the zero position (actuator vented).
2. Should there be an optical position indicator in the actuator (a red spindle), it must be removed.

4.1.2 Assembling the travel sensor

 DANGER	<p>Pretensioned spring!</p> <ul style="list-style-type: none"> ➤ Damage to the device. ● Slowly relax spring.
---	--

	<p>Attention: Damage to the spindle surface may lead to failure of the travel sensor!</p>
---	---

The travel sensor is assembled using a mounting kit 1436S01Z... (direct mounting) or 4232S01Z... (remote mounting) consisting of a spring, an operating bush and a threaded adapter (if applicable). The mounting kit depends on the valve type.

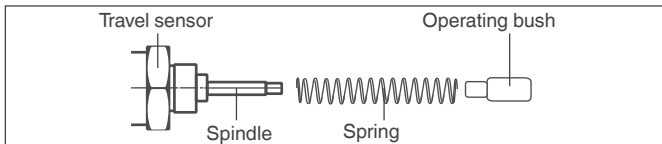

Mounting kit

1. Pull out the spindle of the travel sensor up to the limit stop.

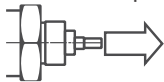

2. Push the spring over the spindle.

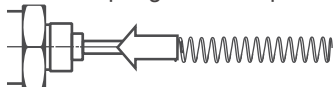

3. Fix the spindle at point **a** (the spindle must not be damaged during this process).

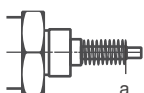

4. Screw the operating bush onto the spindle.

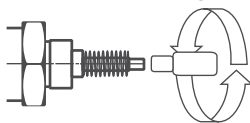

4.1.3 Mounting the positioner



- Mount the positioner **1** by screwing the travel sensor hexagonal nut **SW27 2** into the actuator **3**.

	<p>The positioner must not be fixed by turning the housing as this may result in the danger of overturning the internal stop.</p>
---	---

If correctly mounted to the valve, the positioner can be turned 370°.

4.1.4 Mounting the external travel sensor (only for version with remote mounting)



Valve with external travel sensor

1. Fit positioner **1** somewhere suitable.

	<p>The GEMÜ 1446 00 ZMP mounting bracket (to be ordered separately) can be used to accomplish this.</p>
---	---

2. Assemble the travel sensor (see chapter 4.1.2 "Assembling the travel sensor").
3. Place travel sensor **5** on actuator **3** and attach travel sensor **5** using a suitable open-end wrench **SW27**.

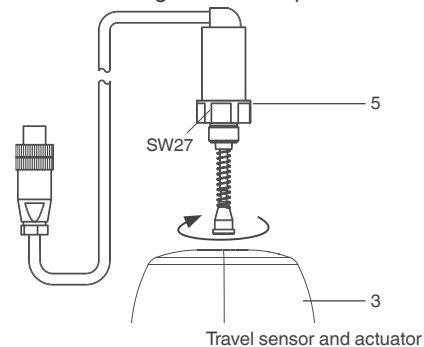

Travel sensor and actuator

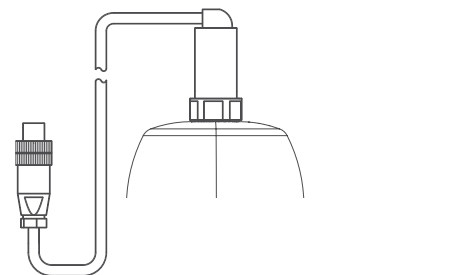

Travel sensor mounted on actuator

4.2 Mounting to quarter turn actuators

4.2.1 Preparation of the valve actuator

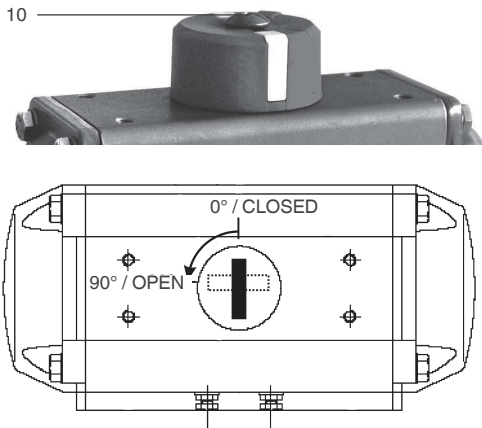

1. The actuator must be in the zero position (actuator vented). Double acting actuators should be moved to the valve "CLOSED" position.
2. Remove the screw **10** which retains the optical position indicator.
3. Determine the turn direction of the actuator (seen from above the turn direction of the actuator must be anticlockwise, when the actuator moves from the "CLOSED" to the "OPEN" position. In cases where the actuator turns in a clockwise direction, the travel sensor's end position, contrary to given instructions, needs to be in the opposite direction).

4.2.2 Assembling the travel sensor

1. Before mounting the travel sensor on the actuator, make sure that the shaft height and the hole pattern in the actuator match the dimensions of the mounting bracket **6**.
2. The travel sensor shaft is marked by a **2**.



Set marking **2** so that it is in correct alignment with the 0° marking on the underside of travel sensor housing **8**.
In the design with an external travel sensor **9**, the 0° marking can be found on the left side of the cable exit (the electrical turn range can be found 90° clockwise from that position).



Information on the positioner:

The slotted holes should be positioned in the centre on the screws. In the case of incorrect travel set up, (determined by checking the attachment, see chapter 4.2.5), the retainer needs to be changed slightly while adapting settings.

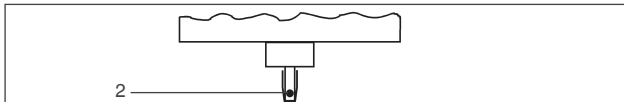

Travel sensor with marking

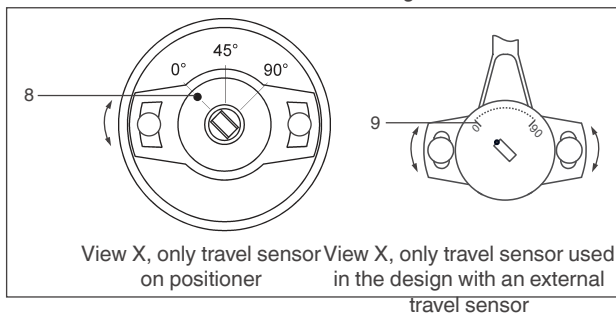

View X, only travel sensor on positioner View X, only travel sensor used in the design with an external travel sensor

View X

3. Place adapter **4** onto the shaft of travel sensor **2** without turning the shaft as you do so.

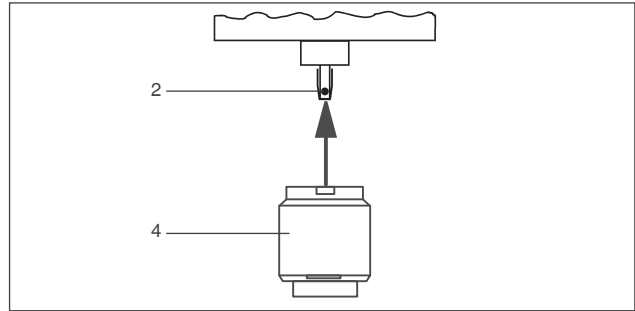

4. Screw positioner **1** or travel sensor **4** onto mounting bracket **6**

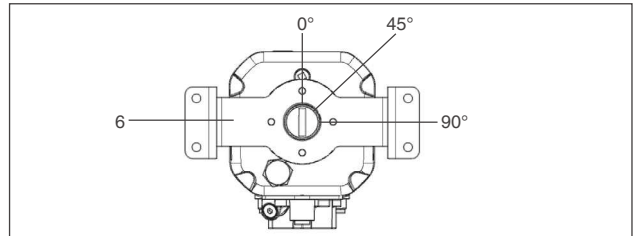
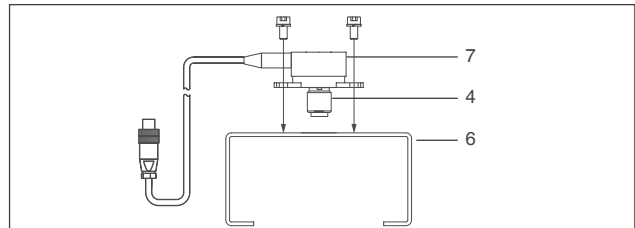
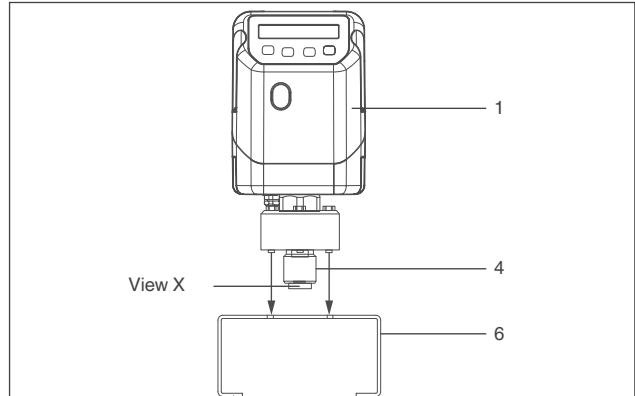

View X with mounting bracket and adapter

4.2.3 Mounting the positioner

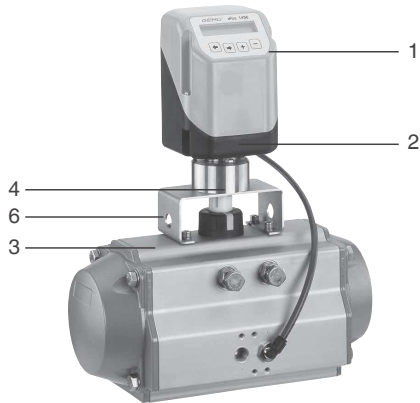

Valve with positioner

1. Place positioner 1 with adapter 4 and mounting bracket 6 on actuator 3.

i The adapter lug 4 must engage in the actuator shaft groove.

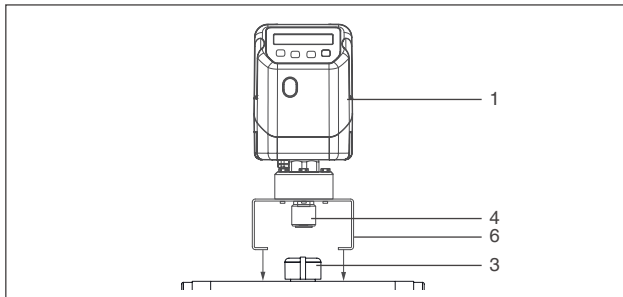

2. Attach mounting bracket 6 to actuator 3 using the screws, washers and spring washers provided.

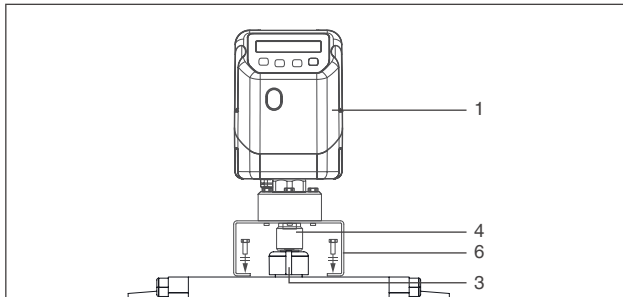

4.2.4 Mounting the external travel sensor (only for version with remote mounting)

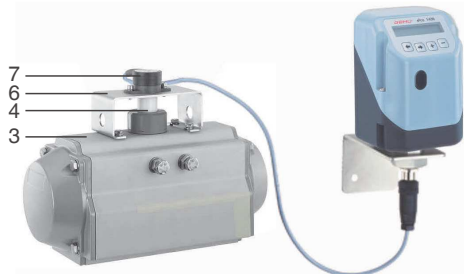

Valve with external travel sensor

i In the design with an external travel sensor, the travel sensor's cable exit protective coating is not UV-resistant and must therefore be protected against direct exposure to weather.

1. Fit positioner 1 somewhere suitable.

i The GEMÜ 1446 00 ZMP mounting bracket (to be ordered separately) can be used to accomplish this.

2. Assemble the travel sensor (see chapter 4.2.2 "Assembling the travel sensor").
3. Place travel sensor 7 with adapter 4 and mounting bracket 6 on actuator 3.

i The adapter lug 4 must engage in the actuator shaft groove.

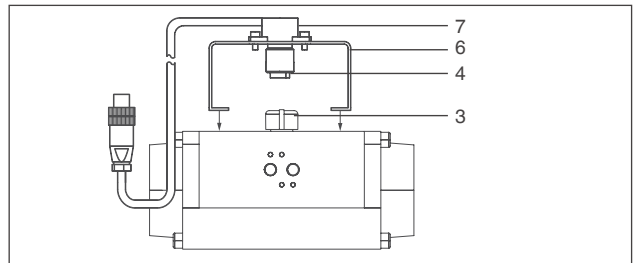

4. Attach mounting bracket 6 to actuator 3 using the screws, washers and spring washers provided.

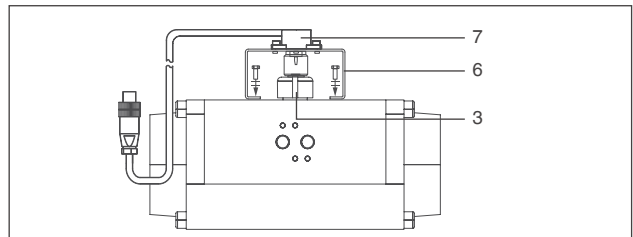

i **Information on the travel sensor:**
The slotted holes should be positioned in the centre on the screws. In the case of incorrect travel set up, (determined by checking the attachment, see chapter 4.2.5), loosen the two screws slightly and twist the travel sensor. Set the travel up correctly and tighten the screws again.

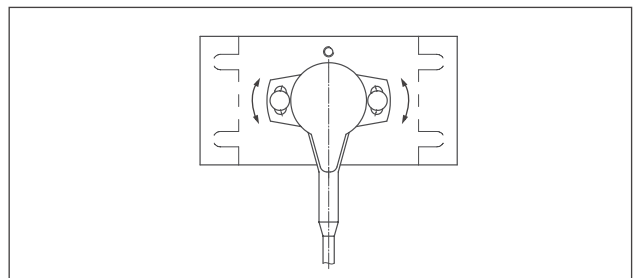

4.2.5 Checking the mounted assembly

1. Connect the positioner to power and air supply (see chapter 5)
2. The following message is displayed:

Nolnit
XX.X%

The mounted actuator can be moved to the OPEN and CLOSED positions using the **+** and **-** keys. The displayed valve position must be between 1 % and 99 %. Should the display show that this range is being exceeded, check the mechanical mounting again and readjust the orientation of the travel sensor, if necessary (see chapter 4.2.2 or 4.2.4).

4.3 Remote mounting to linear or quarter turn actuators

4.3.1 Preparation of the valve actuator

See chapter 4.1.1. or 4.2.1.

4.3.2 Assembling the travel sensor

See chapter 4.1.2. or 4.2.2.

4.3.3 Mounting the external travel sensor (only for version with remote mounting)

See chapter 4.1.4. or 4.2.4.

4.3.4 Checking the mounted assembly

See chapter 4.2.5.

4.3.5 Mounting the mounting bracket



- ✗ Ensure adequate stability of the base used for attachment.
- ✗ The positioner must be protected against mechanical stress by the operator.
- ✗ Do not use the positioner as a climbing support.

1. Push the positioner connection adapter through the hole in the mounting bracket and attach it with the enclosed nut.
2. Use the bolt holes and appropriate fixings to attach the mounting bracket securely.

4.3.6 Connecting the travel sensor

The 5-pin M12 travel sensor plug must be connected to the 5-pin M12 positioner socket.

5 Pneumatic connections



Attention: Observe maximum actuator control pressure!

1. Make the connection between pneumatic positioner outlet A1 (single acting) or A1 and A2 (double acting) and the pneumatic actuator air control inlet.
2. Connect the control air supply (additional air) to the air supply connection P 1 (max. 7 bar or 101 psi).

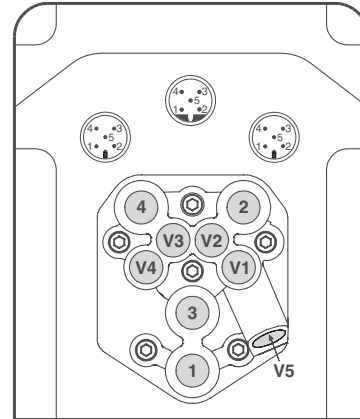

Connection	DIN ISO 1219-1	Description	Size
P	1	Air supply connection	G1/8
R	3	Venting connection with silencer	G1/8
V1	V1	Additional air throttle for A1 (connector 2)	-
V2	V2	Exhaust air throttle for A1 (connector 2)	-
V3	V3	Exhaust air throttle for A2* (connector 4)	-
V4	V4	Additional air throttle for A2* (connector 4)	-
V5	V5	Check valve	-
A1	2	Working connection for process valve (control function 1 and 2)	G1/8
A2	4	Working connection for process valve (control function 3)	G1/8

* only double acting type (code 3)

6 Electrical connections



Danger of cable break!

- Damage to the device.
- Turn electrical connections max. 360°.



To ensure safe restarting of the positioner following interruption of the power supply, the power interruption must be longer than 3 seconds.

1. Connect 24V DC supply voltage to plug X1.
2. Connect analogue input (set value input) 0/4-20 mA to plug X3.
3. If operating as a process controller, connect analogue input (actual value input) 0/4-20 mA to plug X3.

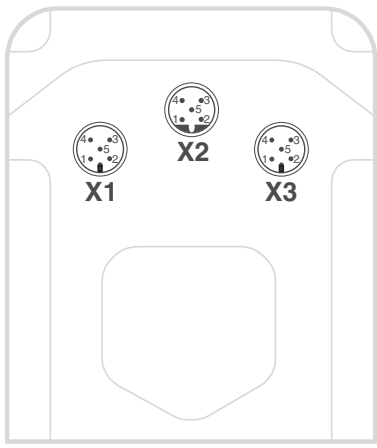

Connection	Pin	Signal name
X1 M12 plug A coding	1	Uv, 24 V DC supply voltage
	2	Switching output K1, 24 V DC (switches Uv*)
	3	GND, (supply voltage, DigIn1+2+W+X; K1+2)
	4	Switching output K2, 24 V DC (switches Uv*)
	5	Digital input 1 (optional**)

Connection	Pin	Signal name
X2 M12 plug B coding	1	I+, actual value output
	2	I-, actual value output
	3	RxD, Receive Data, RS232
	4	TxD, Transmit Data, RS232
	5	GND, RS232

Connection	Pin	Signal name
X3 M12 plug A coding	1	W+, set value input
	2	W-, set value input / Digital In W**
	3	X+, process actual value input
	4	X-, process actual value input / Digital In X**
	5	Digital input 2 (optional**)

* Switching output switches device supply voltage Uv - drop voltage
 ** For options code 01

6.1 Version with external actual value potentiometer (code S01)

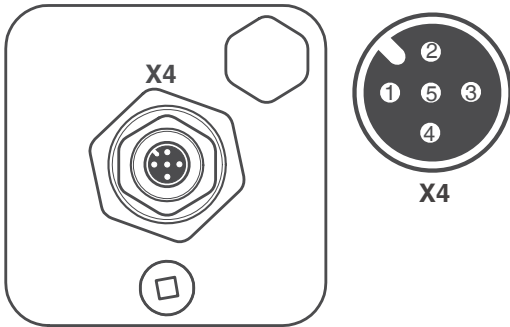

Connection	Pin	Signal name
X4 M12 socket A coding	1	UP+, output potentiometer supply voltage (+)
	2	UP, input potentiometer wiper voltage
	3	UP-, output potentiometer supply voltage (-)
	4	n.c.
	5	n.c.

6.2 Supply voltage

Plug	Pin	Signal name	Wiring
X1	1	24 V DC supply voltage	
X1	3	GND	

6.3 Set value input (only effective for AUTO operating mode)

Plug	Pin	Signal name	Wiring
X3	1	I+, set value input	
X3	2	I-, set value input	

6.4 Actual value input (sensor signal when operating as a process controller)

Plug	Pin	Signal name	Wiring
X3	3	I+, actual value input	
X3	4	I-, actual value input	

6.5 Actual value output

Plug	Pin	Signal name	Wiring
X2	1	I+, actual value output (function freely selectable)	
X2	2	I-, actual value output (function freely selectable)	

6.6 Outputs

Plug	Pin	Signal name	Wiring
X1	2	Output K1	
X1	3	GND	
X1	4	Output K2	

In the menu item **3 SetFunction – K1 Switch / K2 Switch** (chapter 11.5 / 13.3.5) the mode of operation of the outputs can be switched from NO (make-contact) to NC (break-contact).

6.7 Digital inputs

The GEMÜ 1436 cPos makes it possible to use digital inputs for specific functions. It is also available to order with two exclusively digital inputs. In addition to this, it provides the option of using the actual value and set value inputs as digital inputs under certain conditions. The wiring information under 6.7.1 only applies when the GEMÜ 1436 cPos is used without the optional digital input card. The digital inputs facilitate the use of different functions to control the positioner in addition to the analogue control signals. For example, this means up to four parameter sets with different settings can be stored and called up by two digital inputs through a logical connective (ParmSet Bx function). The positioner can be stopped by the signal from a digital input (automatic control system deactivated, current valve position is maintained) or started up by the valve safety position (function OFF/ON or Safe/On). Furthermore, the output source of the analogue actual value output is controlled externally (function Poti/Ix). On the Profibus DP and DeviceNet fieldbus versions, the digital input functions can be used in addition as standard and do not need to be ordered separately.

6.7.1 Use of actual value and set value inputs as digital inputs

The actual value and set value inputs can be used as digital inputs under the following conditions:

Control system	Operating mode	Set value input as digital input "in W"	Actual value input as digital input "in X"
Positioner	AUTO		✓
Positioner	MANUAL	✓	✓
Process controller	AUTO		
Process controller	MANUAL	✓	

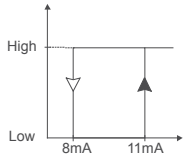

In order to address the two digital inputs "In W" and "In X" a resistor ($R=1.2K\Omega\pm 5\%$) must be connected in series with the input according to the wiring diagram. The switching levels are $> 11mA$ for a High-Signal and $< 8mA$ for a Low-Signal.

Special wiring – Use of set value input as digital input "In W"

Plug	Pin	Signal name	Wiring
X3	1	I+, set value input	
X3	2	I-, set value input	

Special wiring – Use of actual value input as digital input "In X"

Plug	Pin	Signal name	Wiring
X3	3	I+, actual value input	
X3	4	I-, actual value input	

6.8 Digital inputs (optional)

The GEMÜ 1436 cPos has four digital inputs when a digital input card is installed.

The actual value and set value inputs can be used as digital inputs under the following conditions:

Control system	Operating mode	Set value input as digital input "in W"	Actual value input as digital input "in X"
Positioner	AUTO		✓
Positioner	MANUAL	✓	✓
Process controller	AUTO		
Process controller	MANUAL	✓	

Use of set value input as digital input "In W"

Plug	Pin	Signal name	Wiring
X3	2	I-, set value input	
X1	3	GND	

Use of actual value input as digital input "In X"

Plug	Pin	Signal name	Wiring
X3	4	I-, actual value input	
X1	3	GND	

Digital inputs 1 and 2

Plug	Pin	Signal name	Wiring
X1	5	Digital input 1	
X1	3	GND	
X3	5	Digital input 2	
X3	5	Digital input 2	

6.9 RS232 – Interface

Plug	Pin	Signal name	Wiring
X2	3	RxD, Receive Data	
X2	4	TxD, Transmit Data	
X2	5	GND	

M12 socket, B-coded, 5-pin

D-SUB connector 9-pin

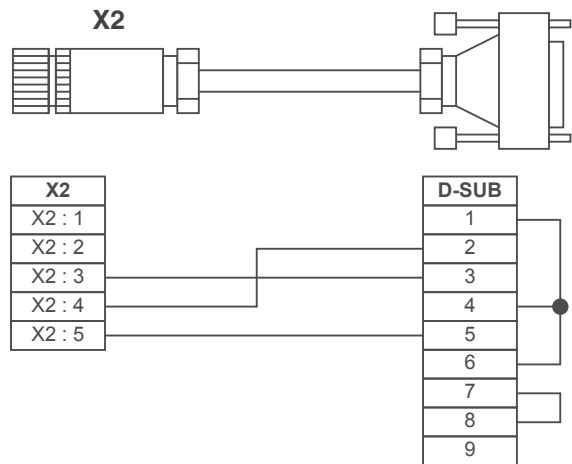

7 Operation

7.1 Operating and display elements

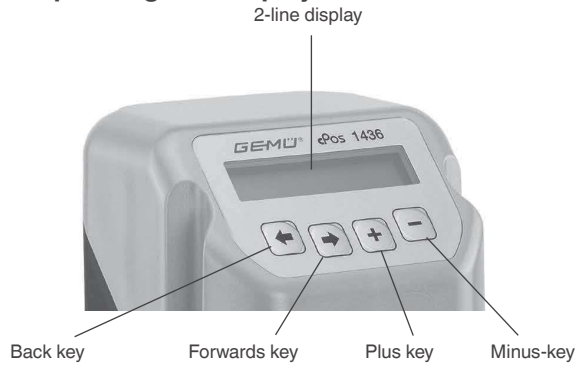

7.2 Menu levels

The GEMÜ 1436 cPos uses two menu levels. These are the working level (Mode) and the configuration level (Setup).

7.2.1 Working level (Mode)

The GEMÜ 1436 cPos is automatically at this level after the supply voltage is switched on.

The menu item Mode can be used to select between the operating modes **A (Auto)**, **M (Manual)**, **F (Manual-Flex)**, **T (Test)** and **OFF**.

A (AUTO):

The positioner is triggered by an external set value signal when using the **AUTO** operating mode.

The positioner also processes an external actual value signal when operated as a process controller.

M (MANUAL):

If **MANUAL** is selected together with operation as a positioner, the valve can be opened and closed manually using the + and - keys.

If **MANUAL** is selected together with operation as a process controller, the set value can be changed manually using the + and - keys.

When switching from **AUTO** to **MANUAL** the last set value input when **MANUAL** was last selected is adopted.



F (MANUAL-FLEX):

If **MANUAL-FLEX** is selected together with operation as a positioner, the valve can be opened and closed manually using the + and - keys.

If **MANUAL-FLEX** is selected together with operation as a process controller, the set value can be changed manually using the + and - keys.

When switching from **AUTO** to **MANUAL-FLEX** the last set value connected under **AUTO** is adopted.



T (Test):

In **TEST** mode in the standard setting as positioner the device may be operated manually for test purposes. It does not process any external input signals and works as a mere positioner.

OFF:

If switched to **OFF** the positioner is in pause mode and then does not react to any changes to the input signals.

7.2.2 Configuration level (Setup)

Various parameters can be set at this level (see Menu structure chapter 11.3) in order to realise optimal adaptation to the application conditions.

8 Changing parameters

For the GEMÜ 1436 cPos the keys \leftarrow \rightarrow $+$ $-$ are used to select the various menus according to chapter 11. Configuration menu.

The changes to the parameters required are made using brackets that are put round the respective parameters.

Use the \leftarrow or \rightarrow key to move the cursor onto the respective parameter and change it with the $+$ or $-$ key.

Example:

The operating mode is to be changed from **OFF** to **Auto**.

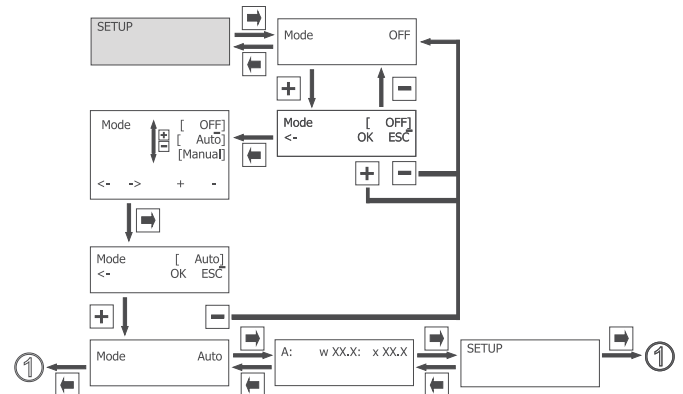

9 Commissioning



If the GEMÜ 1436 cPos is delivered fully mounted to a valve ex works, it is already preset at the factory (at a control pressure of 5.5 - 6 bar without operating pressure) and is therefore ready for operation. A reinitialisation (see chapter 9.2.1) is recommended if the plant is operated with a different control pressure or if the mechanical end positions have been changed (e.g. seal replacement on the valve or actuator replacement).

1. Turn on the pneumatic control air supply (observe maximum control pressure for the positioner and the valve!).
2. Switch on the 24V DC power supply [plug X1, pin 1 (+) and pin 3 (-)].
3. Specify an analogue set value 0/4-20 mA.
4. Specify an analogue actual value (only when operating as a process controller) 0/4-20 mA.

9.1 General information



Exhaust air and cycle duties generate noise!

- ▶ Hearing damage.
- Wear hearing protection.



In order to be able to make changes to settings and parameters for the GEMÜ 1436 cPos no parts of the housing need be taken apart or opened! All parameter settings and the initialisation are retained even in the event of voltage cutoff.

9.2 Initial commissioning without factory setting (when supplied without a valve)



It may be necessary to close the internal positioner throttles a little (V1 and V2 for single acting actuators and V1, V2, V3 and V4 for double acting actuators) if the actuator volume is very low in order to increase the valve operating time. This can be done during initialisation in "adjTime". A modification to the throttle setting independent of initialisation may lead to error messages and/or poor control results. It is therefore recommended to carry out initialisation again after every throttle change.



Experience has shown that valve operating times of about 1-2 seconds lead to optimal control results. It may not be possible to reach this operating time range for large-volume actuators.



For valves with control function 8 (double acting with opening spring), for which automatic control function recognition has not worked, the parameter "CtrlFn" must be converted to "DNO" in the manual initialisation sequence.

After assembly and all electrical and pneumatic connections, the positioner must be initialised.

While doing this, it is possible to choose between **automatic initialisation** and **manual initialisation**.

When connecting the supply voltage, the following message is displayed by GEMÜ 1436 cPos after it has completed a short software check:

NoInit XX.X%

Use the **+** and **-** keys to open and close the valve.

9.2.1 Automatic initialisation



Tip for use:

During automatic initialisation of actuators whose travel is not continuous (i.e. with undefined stops, e.g. with large size butterfly valves) the end positions cannot be clearly detected. In this case manual initialisation by the operator with sequential movement through the menu (see chapter 9.2.2) should be used.



Automatic initialisation can also be carried out by quick commissioning (see Quick Commissioning on page 2 of the GEMÜ 1436 cPos).

The positioner adapts to the valve when automatic initialisation is started. All parameters are automatically scanned.

This procedure can take a few minutes, dependent on the valve.

- Prior to commissioning, familiarise yourself with the operation of the GEMÜ 1436 cPos (see chapter 7).
- For automatic initialisation proceed as described on the next page.

9.2.2 Manual initialisation

When manual initialisation is started, the positioner runs through an initialisation program that is similar to the automatic initialisation. However the different program steps for the manual initialisation must be started and confirmed by the operator using the **+** key.

- Manual initialisation should only be used if the automatic initialisation does not achieve satisfactory control features or in case of leakage problems.
- The menu items **goClose** and **goOpen** should be carried out several times for very small valve strokes in order to ensure an optimum adaptation of the positioner to the valve.
- Emergency operation of the automatic control system is possible, if at least the **goClose** and **goOpen** menu items are carried out.
- In order to prevent incorrect operation, the parameters from manual initialisation are only accepted when they comply with the requirements for correct function.
- Prior to commissioning, familiarise yourself with the operation of the GEMÜ 1436 cPos (see chapter 7).
- For manual initialisation proceed as described on the next page.

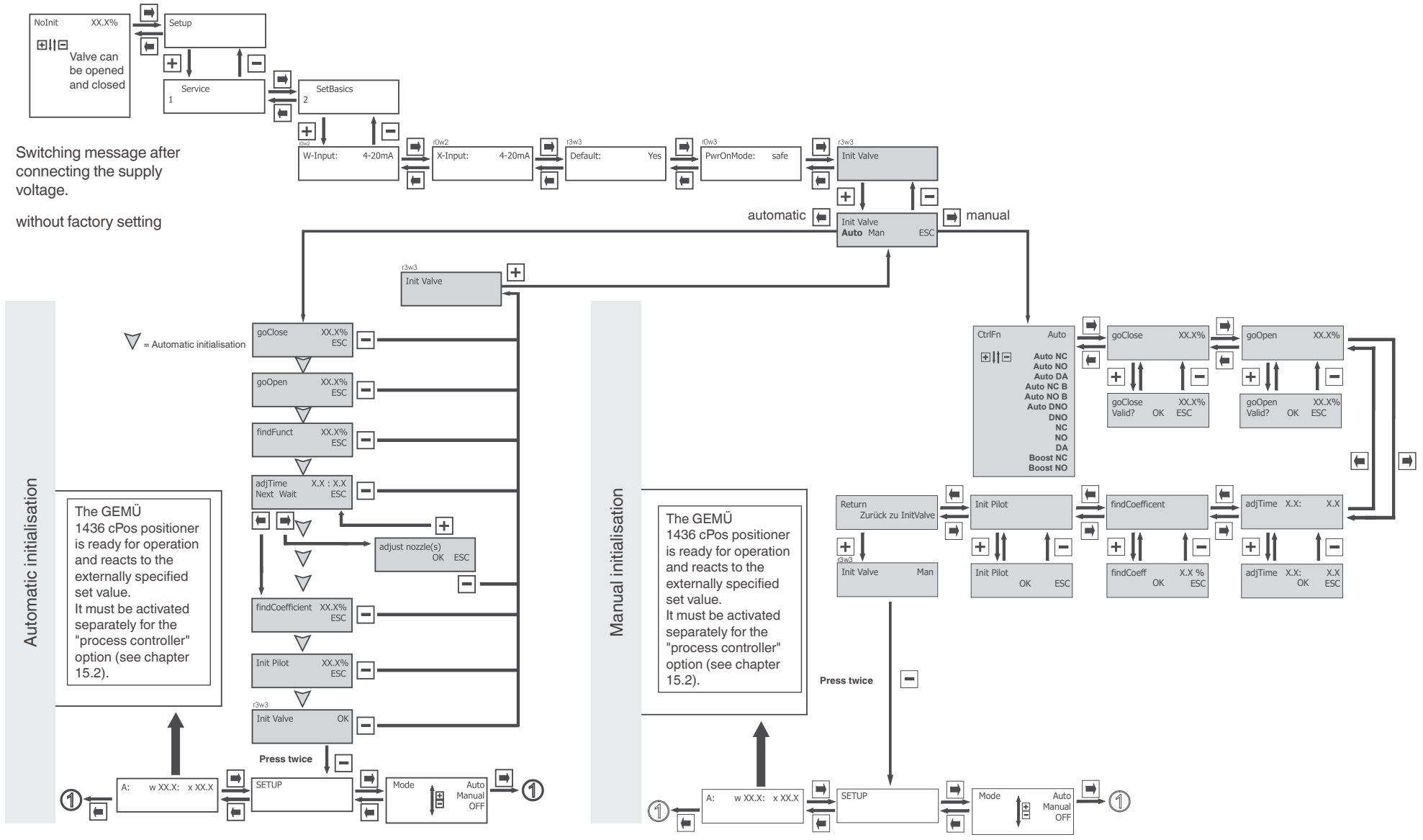

Switching message after connecting the supply voltage.

without factory setting

▽ = Automatic initialisation

Automatic initialisation

Manual initialisation

The GEMÜ 1436 cPos positioner is ready for operation and reacts to the externally specified set value. It must be activated separately for the "process controller" option (see chapter 15.2).

The GEMÜ 1436 cPos positioner is ready for operation and reacts to the externally specified set value. It must be activated separately for the "process controller" option (see chapter 15.2).

Press twice

Press twice

9.2.4 Error messages during initialisation

No.	Error text	Description	Condition for the occurrence of the error	Error cause
020	Pot wrong dir Error	The potentiometer has recognised the wrong control function during initialisation.	Parameter "CtrlFn" is set to AUTO and a valve with control function 3 is recognised, from which the actuator has moved in the wrong direction. Parameter "CtrlFn" is set for a fixed control function. This set control function is not in accordance with the control function determined during initialisation.	The pneumatic connections for "CLOSED" and "OPEN" on the valve have been switched or the parameter "Pot Dir" is set on "fall". The wrong control function is set.
021	Wrong function Error	An incorrect control function was recognised during automatic initialisation.	Parameter "CtrlFn" is set for a fixed control function. This set control function is not in accordance with the control function determined during initialisation.	The wrong control function is set in the "CtrlFn" parameter. If the parameter is set to AUTO, the 1436 cPos determines the corresponding control function and leaves it there (this does not apply for control function 8 – carry out manual initialisation in this case, or set the parameter "CtrlFn" to "DNO").
022	Pneumatic Error Error	During automatic initialisation of the valve a pneumatic error was detected.	<ul style="list-style-type: none"> ● The minimum stroke was undershot ● End positions cannot be reached ● Leakage in the system 	Check the stroke of the pneumatic system. Check leakage and end positions.
023	Leakage Error	During automatic initialisation of the valve leakage was detected.	The positioner is in initialisation mode.	Check the pneumatic system for leakage and carry out initialisation again.
060	TrvlSensErr Error	A cable break or short-circuit in the sensor connection (travel sensor) was detected.		Cable break or short-circuit in the sensor connection (travel sensor) detected.

	Error text	Description	Condition for the occurrence of the error	Error cause
	In 1 no Signal	No signal at digital input In 1	Parameter In 1 is set to OFF / ON or Safe / ON	Connect signal to digital input In 1
	In 2 no Signal	No signal at digital input In 2	Parameter In 2 is set to OFF / ON or Safe / ON	Connect signal to digital input In 2
	In W no Signal	No signal at digital input In W	Parameter In W is set to OFF / ON or Safe / ON	Connect signal to digital input In W
	In X no Signal	No signal at digital input In X	Parameter In X is set to OFF / ON or Safe / ON	Connect signal to digital input In X

9.2.5 Initialisation parameters

InitValve:

Automatic or manual initialisation (adaptation of the positioner to the valve) is started.

CtrlFn:

The control function type for the valve can be selected during manual initialisation (see table on page 16).
This setting also influences subsequent automatic initialisations.

goClose:

The closed valve position is scanned during initialisation. This function must be started with the  key if initialising manually and then confirmed.

goOpen:

The open valve position is scanned during initialisation. This function must be started with the  key if initialising manually and then confirmed.

findFunct:

(only available for automatic initialisation)
The valve control function is determined.

adjTime:

(only displayed when "goOpen" and "goClose" were carried out)
The minimum operating times for the valve are scanned during initialisation.
This function must be started with the  key if initialising manually.

findCoefficient:

(only displayed if "adjTime" was carried out)
The valve is checked for control features at various positions between the end positions.

CalPointQty:

The quantity of calibration points when initialising can be changed.
Example:
QtyCalPoint=9 means:
The valve will be examined for control features between the end position stops in 9 positions (10 % steps here).

Init Pilot:

The minimum operating times for the internal pilot valves are adjusted to the process valve.
This function must be started with the  key if initialising manually.

After initialisation various messages may appear in the display depending on the status determined at initialisation:

Init Valve OK:

The initialisation was carried out successfully.
No errors were determined during initialisation.
The positioner is ready for operation.

Init Valve Man:

The initialisation was carried out manually.
The end positions were determined successfully.
Any other possible errors are not taken into consideration for manual initialisation.
The positioner is ready for operation.



Init Valve Error:

An error was determined during initialisation.
Operation is not possible.
Check the mechanical mounting and the pneumatic system.
Then carry out the initialisation again.
Carrying out manual initialisation enables emergency operation.

Init Valve ESC:

The initialisation was aborted by the user.
Emergency operation of the automatic control system is possible, if at least the **goClose** and **goOpen** menu items are carried out.

9.3 Initial commissioning with factory setting (positioner supplied mounted to the valve)

	If the GEMÜ 1436 cPos was already fully mounted to a valve in the factory, it is already factory preset and therefore immediately operable. We recommend reinitialisation in order to compensate control pressure differences. Please proceed as described in chapter 9.2.1.
	To switch between the operating modes, proceed according to 10. Operating modes .

When connecting the supply voltage, the GEMÜ 1436 cPos emits one of the following two messages in its display after a short software check:

A: w XX.X: x XX.X

or

M: w XX.X: x XX.X

A: Positioner in automatic mode

M: Positioner in manual mode

Overview of initialisation parameter CtrlFn

Parameter	Value	Description	Automatic initialisation function	Manual initialisation function ⁴⁾
CtrlFn	Auto	Automatic search of the control function during automatic initialisation. Complies with manual initialisation of control function 1 (NC).	Automatic detection of the control function	Complies with NC ²⁾ setting. If the valve control function differs, do not use this setting.
	Auto NC	Control function 1 (closed by spring force) with automatic adaptation/modification for automatic initialisation	Automatic detection and modification of the control function	Control function 1 (normally closed)
	Auto NO	Control function 2 (opened by spring force) with automatic adaptation/modification for automatic initialisation	Automatic detection and modification of the control function	Control function 2 (opened by spring force)
	Auto DA	Control function 3 (double acting) with automatic adaptation/modification for automatic initialisation	Automatic detection and modification of the control function	Control function 3 (double acting)
	Auto NC B ³⁾	Control function 1 (closed by spring force) – for increased controller air output (only 300 l/min) with automatic adaptation/modification during automatic initialisation	Automatic detection and modification of the control function	Control function 1 (closed by spring force) – with increased controller air output (only 300 l/min)
	Auto NO B ³⁾	Control function 2 (opened by spring force) – for increased controller air output (only 300 l/min) with automatic adaptation/modification during automatic initialisation	Automatic detection and modification of the control function	Control function 2 (opened by spring force) – with increased controller air output (only 300 l/min)
	Auto DNO ¹⁾	Control function 8 (double acting with opening spring) – with automatic adaptation/modification for automatic initialisation	Automatic detection and modification of the control function ¹⁾	Control function 8 (double acting with opening spring)
	DNO ¹⁾	Control function 8 (double acting with opening spring)	Control function 8 (double acting with opening spring)	Control function 8 (double acting with opening spring)
	NC ²⁾	Control function 1 (normally closed)	Control function 1 (normally closed)	Control function 1 (normally closed)
	NO ²⁾	Control function 2 (normally open)	Control function 2 (normally open)	Control function 2 (normally open)
	DA ²⁾	Control function 3 (double acting)	Control function 3 (double acting)	Control function 3 (double acting)
	Boost NC ^{2) 3)}	Control function 1 (closed by spring force) – with increased controller air output (only 300 l/min)	Control function 1 (closed by spring force) – with increased controller air output	Control function 1 (closed by spring force) – with increased controller air output (only 300 l/min)
	Boost NO ^{2) 3)}	Control function 2 (opened by spring force) – with increased controller air output (only 300 l/min)	Control function 2 (opened by spring force) – with increased controller air output	Control function 2 (opened by spring force) – with increased controller air output (only 300 l/min)

¹⁾ The fixed control function setting "DNO" should be used for valves with control function 8 (double acting with opening spring). When using the "Auto DNO" setting, a deviating control function may be incorrectly detected during an automatic initialisation and the initialisation cannot be completed. The "Wrong Function" error message appears.

²⁾ Fixed control functions (NC, NO, DA, Boost NC and Boost NO) must match in terms of the actuator's control function. An incorrect assignment may lead to faults and/or inverted action, and should therefore only be used if the correct control function is known. In case of doubt, give preference to an "auto" detection.

³⁾ On versions with 300 l/min flow capability (booster), double the number of pilot valves is fitted and connected in parallel. If, in these versions, a control function is set for simple pilot valves, this leads to a reduction in the flow capability.

⁴⁾ A manual initialisation should only ever be carried out if you have not achieved satisfactory control characteristics with the automatic initialisation or this was aborted due to an error message.

10 Operating modes

The GEMÜ 1436 cPos uses the operating modes **A: AUTO**, **M: MANUAL**, **F: MANUAL-FLEX**, **T:TEST** and **OFF**.

10.1 Operating mode selection

Selection of the operating mode and entering the configuration menu is carried out in the following menu.

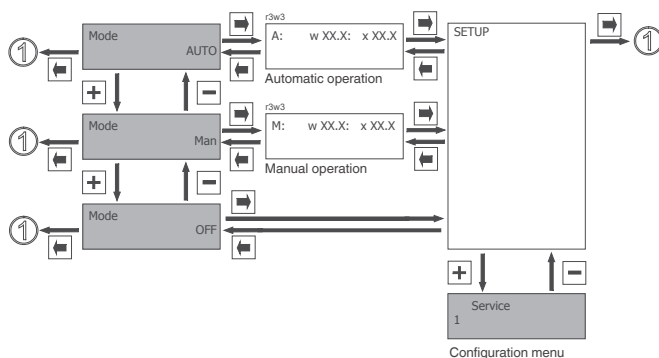

10.2 Automatic operation (A:)

Automatic operation is the normal operating mode. The initialised positioner responds to set value changes and adjusts the valve accordingly.

The **+** and **-** keys have no function in this operating mode. When operating the device as a positioner, the display on the top left-hand side is operating mode (A), in the middle the current set value (w) and on the top right-hand side the current valve position (x) as a percentage.

When operating the device as a process controller, the display on the top left-hand side is operating mode (A), in the middle the current set value (w) and on the top right-hand side the current actual value (x) of the externally connected process sensor.

10.3 Manual operation (M:)

If **MANUAL** is selected together with operation as a positioner, the valve can be opened and closed manually using the **+** and **-** keys.

If **MANUAL** is selected together with operation as a process controller, the set value can be changed manually using the **+** and **-** keys.

When switching from **AUTO** to **MANUAL** the last set value input when **MANUAL** was last selected is adopted.

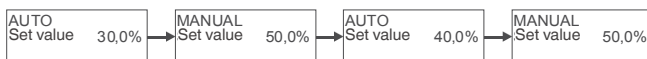

10.4 Manual operation with flexible set value specification (F:)

If **MANUAL-FLEX** is selected together with operation as a positioner, the valve can be opened and closed manually using the **+** and **-** keys.

If **MANUAL-FLEX** is selected together with operation as a process controller, the set value can be changed manually using the **+** and **-** keys.

When switching from **AUTO** to **MANUAL-FLEX** the last set value connected under **AUTO** is adopted.



10.5 Test mode (T:)

Test mode serves for test purposes to enable quick access to the basic settings as a positioner. Parameter changes in the test mode are valid only in this operating mode.

10.6 Pause mode (OFF)

If switched to **OFF** the positioner is in pause mode and then does not react to any changes to the input signals.

11 Configuration menu (Setup)

Various parameter values of the GEMÜ 1436 cPos can be changed in the configuration menu. The parameter name appears in the top left line of the display and the parameter value on the right.

In order to enable immediate use of the GEMÜ 1436 cPos, the most common values were entered as factory settings.



The submenus which are only required for the process controller are only available for the design with integrated process controller (PA01).

The relevant submenus are highlighted in grey.

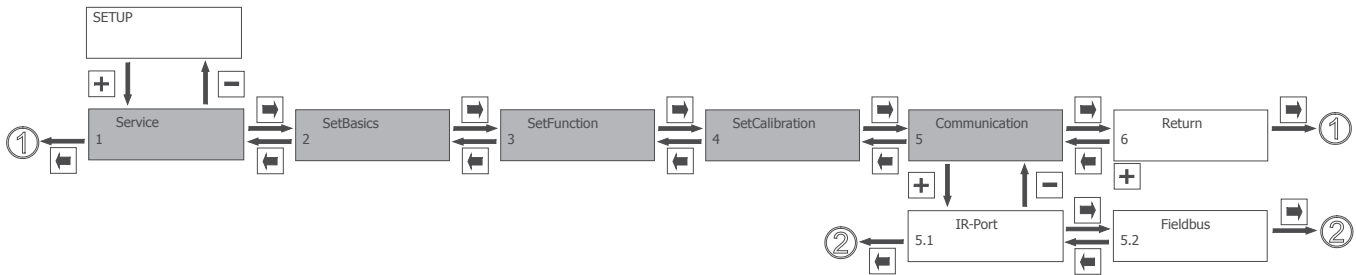

The configuration menu consists of five submenus with the following functions:

1. Service

This menu is used to read out all information/diagnostics regarding the positioner, the connected signals and errors that occur.

2. SetBasics

SetBasics is used to set the basic settings for the GEMÜ 1436 cPos such as the initialisation, selection of input signals and resetting to factory settings.

3. SetFunction

The special positioner functions are activated or deactivated here and the control parameters set.

4. SetCalibration

SetCalibration is used to set the directions of action, characteristic curves, stroke limits and closing limits and error limit values.

5. Communication

The different communication options for the GEMÜ 1436 cPos can be set here.

11.1 Changes in the configuration menu

Changes can be made to the factory settings according to the menu overview below.

Before making changes in the configuration menu, familiarise yourself with the operation of the GEMÜ 1436 cPos (see chapter 7).

In this case, the small squares represent the GEMÜ 1436 cPos keys that must be pressed to reach the next menu item or within the menu to the various settings.

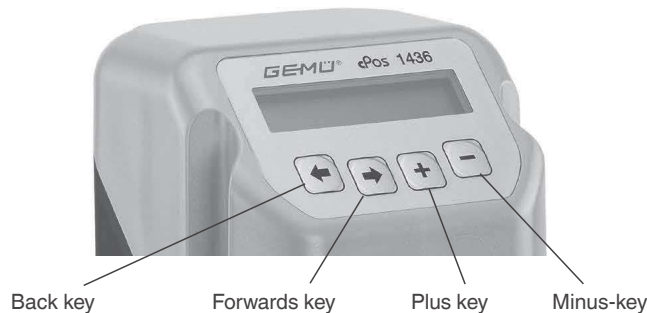

11.2 Access authorisation in the configuration menu

In order to hinder unwanted changes to the parameter values, the configuration level of the GEMÜ 1436 cPos is secured with three different access codes.

The factory code setting is as follows:

Code 1: Password **0** (New Code: 1)
Code 2: Password **0** (New Code: 2)
Code 3: Password **0** (New Code: 3)

After entering the factory codes, these codes can be changed by the operator at any time.

The access priorities needed are marked in the configuration menu.

In order to change the access codes, please refer to **13.1.2. Activating or deactivating the user access.**

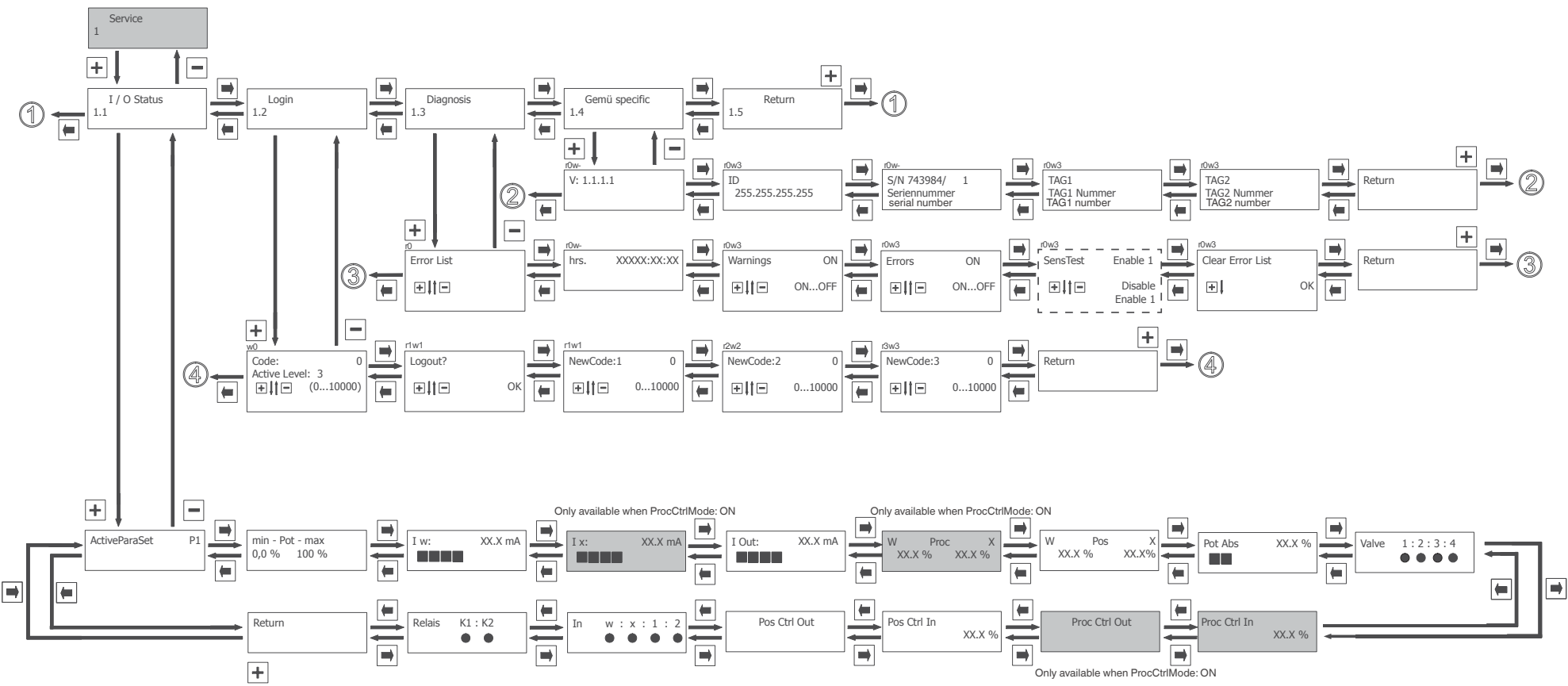

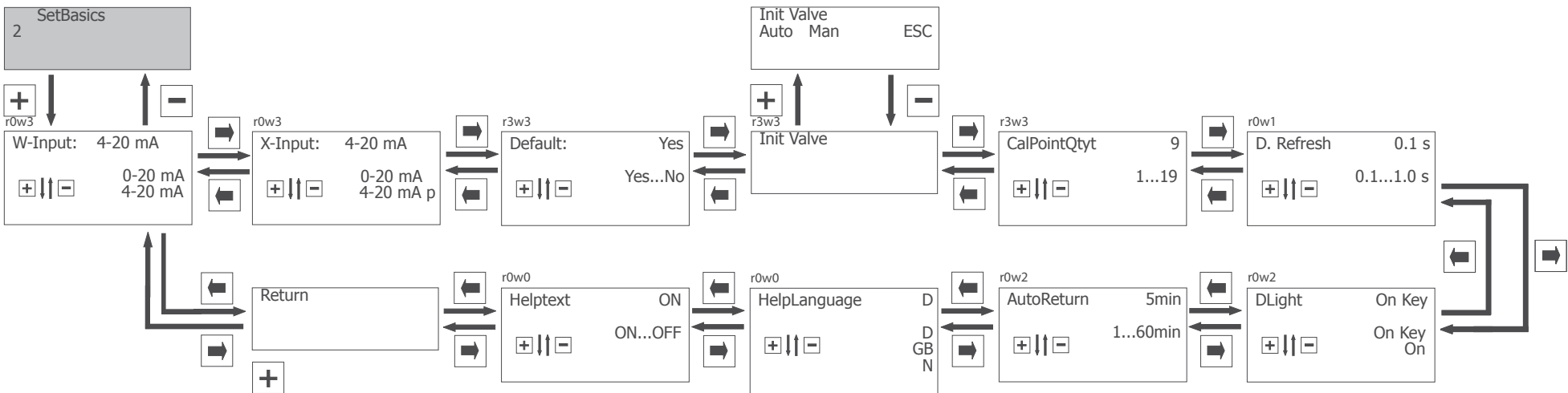

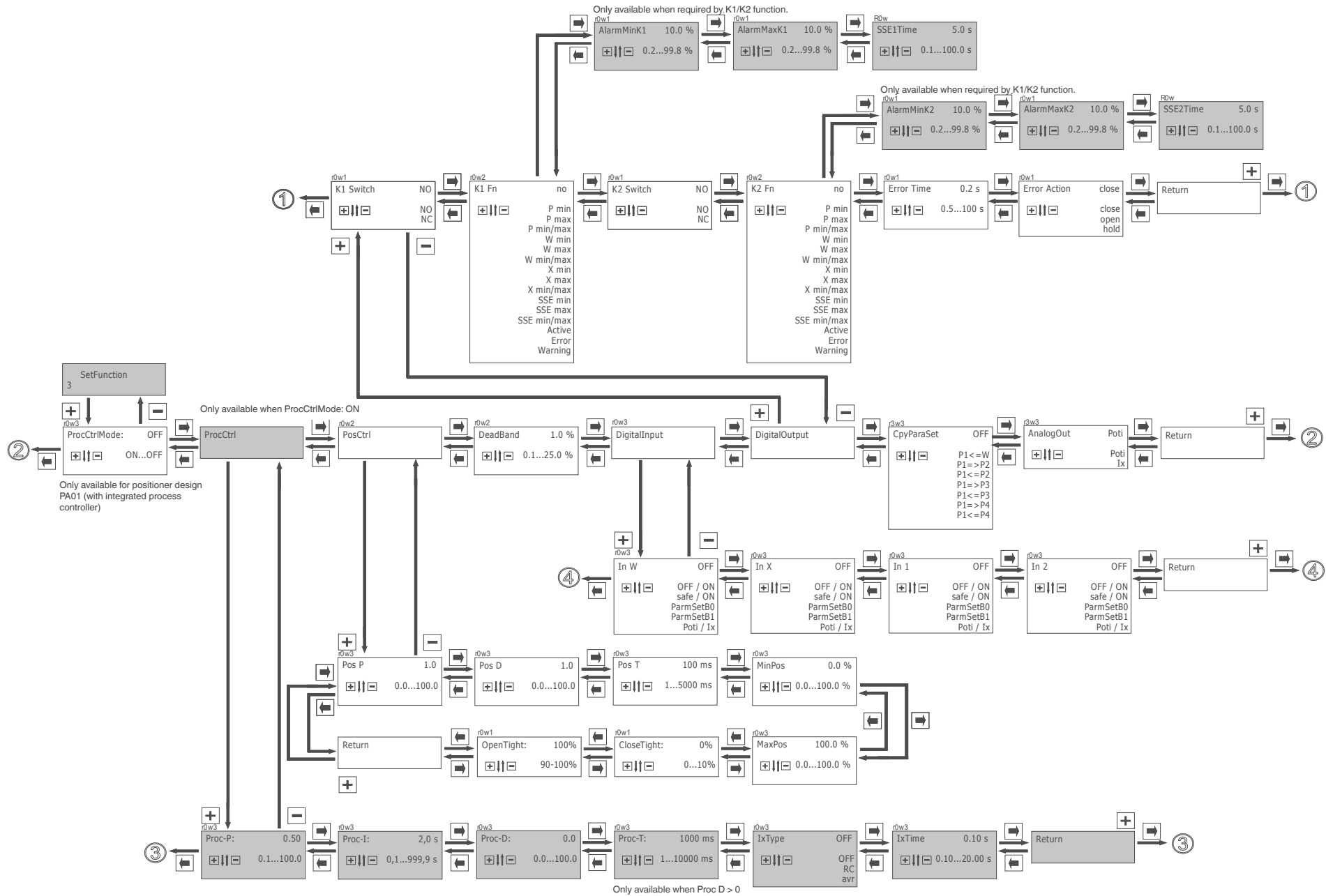

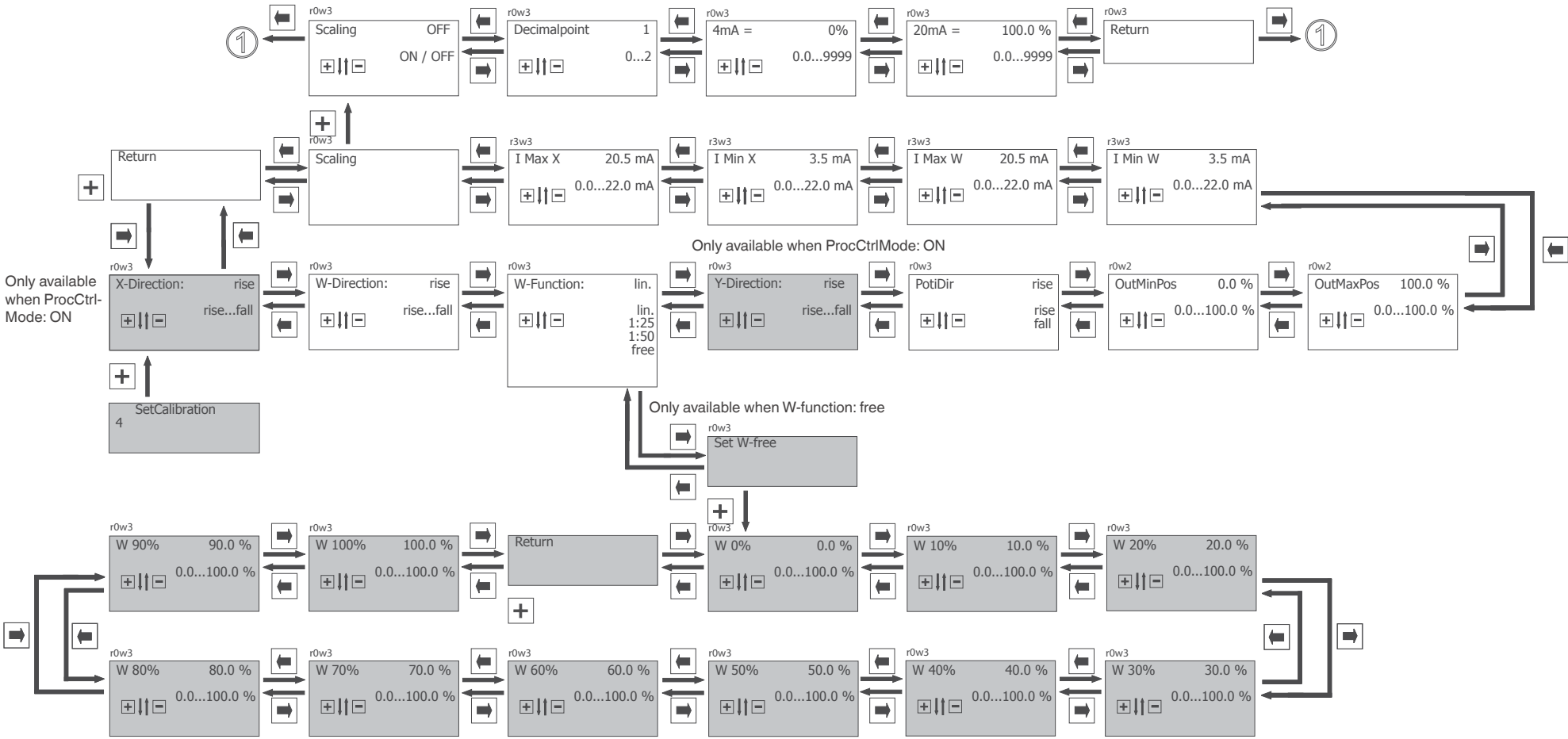

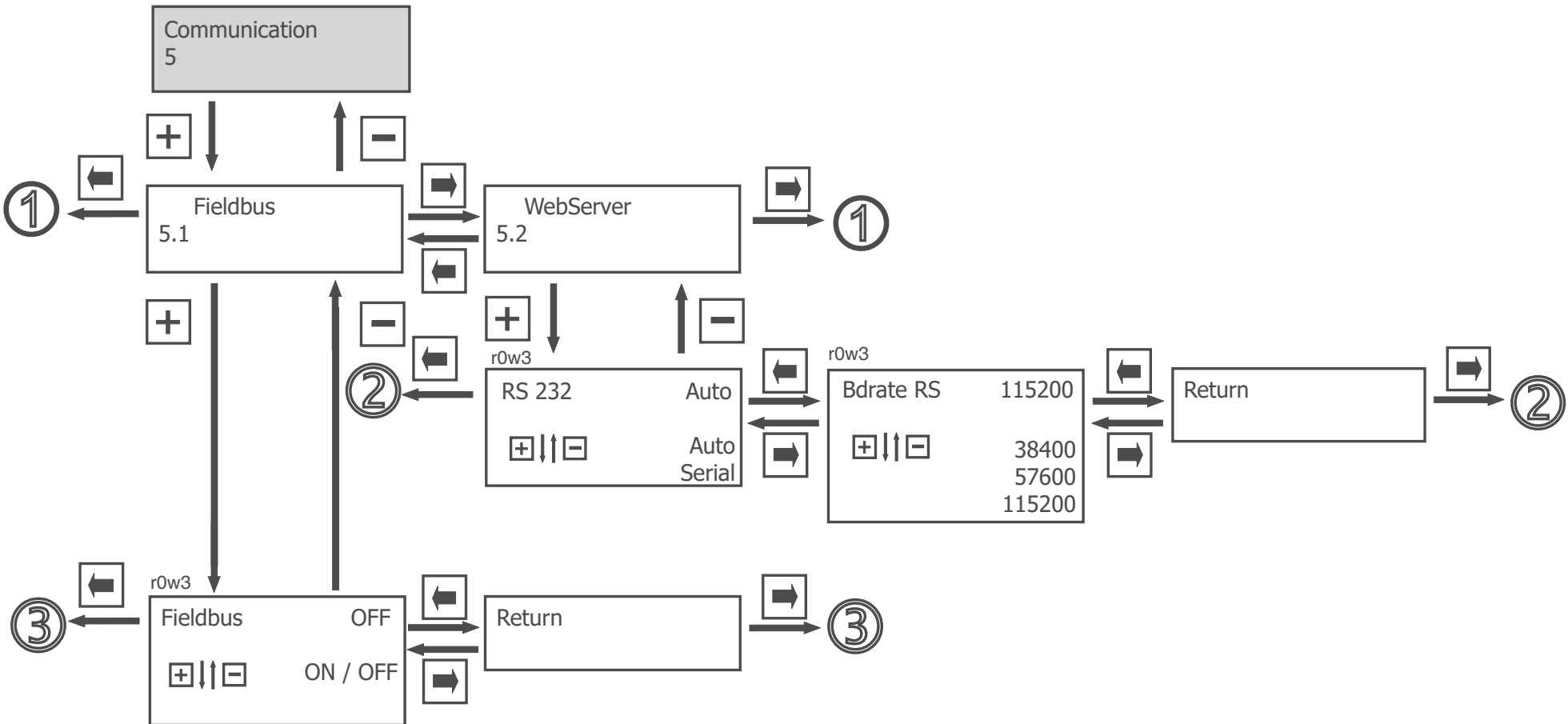

12 Parameter table

Configuration level	Display	Function	Value range	Factory setting	
	Mode	Select operating mode	AUTO MAN MAN-FLEX TEST OFF	AUTO	
1 Service	Submenu for displaying inputs and outputs				
	ActiveParaSet	Displays the current active parameter set	P1 ... P4	P1	
	min-Pot-max	Displays travel sensor position in percent			
	I w	Value of set value signal in mA			
	I x*	Value of actual value signal in mA as a process controller			
	I Out	Value of actual value output in mA			
	W Proc X*	Value of set value signal in relation to actual value signal			
	W Pos X	Comparison of set value and valve position			
	Pot Abs	Travel sensor position			
	Valve 1:2:3:4	Displays the current position of the internal pilot valves			
	Proc Ctrl In*	Deviation between set value and actual value (process controller) (%)			
	Proc Ctrl Out*	Deviation between set value and actual value (process controller)			
	Pos Ctrl In	Deviation between set value and actual value (positioner) (%)			
	Pos Ctrl Out	Deviation between set value and actual value (positioner)			
	In w:x:1:2	Displays the current signals of the digital inputs			
	Relais K1:K2	Displays the current position of the internal outputs			
	Submenu for setting access authorisations				
	Login	Code	Password entry	0...10000	0
		Logout	Block access	OK	
		New Code: 1	Release the lowest priority	0...10000	0
		New Code: 2	Release the medium priority	0...10000	0
		New Code: 3	Release the top priority	0...10000	0
	Submenu for displaying diagnostic messages				
	Diagnosis	Error List	Displays error messages		
		hrs	Displays operating hours		
		Warnings	Display warnings during operation	ON / OFF	ON
		Errors	Display errors during operation	ON / OFF	ON
		SensTest	Switch sensor test on or off	Disable / Enable1	Disable
		Clear Error List	Delete error list	OK	
	Submenu for displaying the tool identification				
	1436 specific	V:1.1.1.1	Displays current software version		
		S/N xxx	Displays current serial number		
		TAG1	11-digit ID number can be set		
TAG2		11-digit ID number can be set			

*Only for activated process controllers

Configuration level	Display	Function	Value range	Factory setting	
2 SetBasics	W-Input	Type of set value signal	4-20 mA / 0-20 mA	4-20 mA	
	X-Input*	Type of actual value signal	4-20 mA p / 0-20 mA	4-20 mA p	
	Default	Reset to factory settings	Yes / No	Yes	
	Submenu for carrying out the initialisation				
	Init Valve	GoClose	Scanning the closed position		
		GoOpen	Scanning the open position		
		FindFunct	The valve control function is determined		
		AdjTime	Scanning the operating times		
		FindCoefficient	Optimising the control features		
		Init Pilot	Setting the minimum operating times for internal pilot valves		
	CalPointQty	Quantity of calibration points when initialising	1...19	9	
	D.Refresh	Time for display refresh	0.1...1.0 s	0.1 s	
	DLight	Setting the display lighting	OnKey / On	OnKey	
	AutoReturn	Time for an automatic return to the working level - Setup	1...60min	5min	
	HelpLanguage	Text language	D / GB / N	D	
HelpText	Display the help text	ON / OFF	ON		

Configuration level	Display	Function	Value range	Factory setting	
3 SetFunction	ProcCtrlMode*	Switch process controller on or off	ON / OFF	OFF	
	Submenu for setting process controller parameters				
	ProcCtrl*	Proc-P	KP amplification of the process controller	0.0...100.0	0.5
		Proc-I	KI reset time for the process controller	0.0...999.9s	2.0s
		Proc-D	KD component of the process controller	0.0...100.0	0.0
		Proc-T	Process controller Tv time	1...10000 ms	1000 ms
		IxType	Defines the type of actual value filter	OFF / RC / avr	OFF
		IxTime	Filter time for actual value input	0.10...20.00 s	0.10 s
		Submenu for setting positioner parameters			
	PosCtrl	Pos P	P amplification of the positioner	0.0...100.0**	1.0
		Pos D	D amplification of the positioner	0.0...100.0	0.0
		Pos T	Decay time of the D component of the positioner	1...5000 ms	100 ms
		MinPos	Closing limit = lower position of control range	0...100 %	0.0 %
		MaxPos	Stroke limitation = upper position of control range	0...100 %	100 %
		CloseTight	Lower close tight function	0...20 %	0 %
		OpenTight	Upper close tight function	80...100 %	100 %
		DeadBand	Permissible system deviation	0,1...25 %	1,0 %, K-no. 2442: 2,0 %, K-no. 2443: 5,0 %
	Submenu for setting the digital inputs				
	Digital Input	In W	Determines the function of the digital input "In W"	OFF / ON Safe / ON ParmSetB0 ParmSetB1 Poti / Ix	OFF
		In X	Determines the function of the digital input "In X"	OFF / ON Safe / ON ParmSetB0 ParmSetB1 Poti / Ix	OFF
		In 1	Determines the function of the digital input "In 1"	OFF / ON Safe / ON ParmSetB0 ParmSetB1 Poti / Ix	OFF
		In 2	Determines the function of the digital input "In 2"	OFF / ON Safe / ON ParmSetB0 ParmSetB1 Poti / Ix	OFF

*Only for activated process controllers

** Parameter value is automatically calculated and set by the positioner during initialisation

Configuration level	Display	Function	Value range	Factory setting
3 SetFunction	Submenu for setting the digital outputs			
	K1 Switch	Defines the type of output	NC / NO	NO
	K1 Fn	Determines the function of output K1	NO P min P max P min/max W min W max W min/max X min X max X min/max SSE min SSE max SSE min/max Active Error Warning	no
	AlarmMaxK1	Switch point that switches after K1 is exceeded	0.2...99.8 %	10.0 %
	AlarmMinK1	Switch point that switches after K1 is undershot	0.2...99.8 %	90.0 %
	SSE1Time	Delay time between error recognition and error message to K1	0.1...100.0 s	5.0 s
	K2 Switch	Defines the type of output	NC / NO	NO
	K2 Fn	Determines the function of output K2	no P min P max P min/max W min W max W min/max X min X max X min/max SSE min SSE max SSE min/max Active Error Warning	no
	AlarmMaxK2	Switch point that switches after K2 is exceeded	0.2...99.8 %	10.0 %
	AlarmMinK2	Switch point that switches after K2 is undershot	0.2...99.8 %	90.0 %
	SSE2Time	Delay time between error recognition and error message to K2	0.1...100.0 s	5.0 s
	ErrorTime	Delay time between error recognition and error message	0.5...100 s	0.2 s
	ErrorAction	Function of the process valve if there is an error message	Close/Open/Hold	Close
	CpyParaSet	Copies parameters to various working memories (P1/P2/P3/P4)		
	AnalogOut	Sets the function of analog output	Poti / lx	Poti

Configuration level	Display	Function	Value range	Factory setting	
4 SetCalibration	X-Direction*	Determines the direction of the actual value signal (rising/falling)	rise / fall	rise	
	W-Direction	Determines the direction of the set value signal (rising/falling)	rise / fall	rise	
	W-Function	The control curve is defined	Lin./1:25/1:50/free	lin.	
	Set W-free	10 control curve points can be programmed as desired	W 0 %	0...100 %	0.0 %
			W 10 %	0...100 %	10.0 %
			W 20 %	0...100 %	20.0 %
			W 30 %	0...100 %	30.0 %
			W 40 %	0...100 %	40.0 %
			W 50 %	0...100 %	50.0 %
			W 60 %	0...100 %	60.0 %
			W 70 %	0...100 %	70.0 %
			W 80 %	0...100 %	80.0 %
	W 90 %	0...100 %	90.0 %		
	W 100 %	0...100 %	100.0 %		
	Y-Direction*	Determines the direction of the process controller output (rising/falling)	rise / fall	rise	
	PotiDir	Defines the direction of the actual value potentiometer of the valve	rise / fall	rise	
	OutMinPos	Valve position at actual value output signal 0/4mA	0...100 %	0.0 %	
OutMaxPos	Valve position at actual value output signal 20mA	0...100 %	100.0 %		
I Min W	Switch-off limit for cable break recognition of the set value	0.0...22.0 mA	3.5 mA		
I Max W	Switch-off limit for excess current recognition of the set value	0.0...22.0 mA	20.5 mA		
I Min X	Switch-off limit for cable break recognition of the actual value	0.0...22.0 mA	3.5 mA		
I Max X	Switch-off limit for excess current recognition of the actual value	0.0...22.0 mA	20.5 mA		
Scaling	Submenu for scaling the actual value and set value display				
	Scaling	Switches the scaled display on	ON / OFF	OFF	
	Decimalpoint	Determines the number of digits displayed after the decimal point	0...2	1	
	4 mA ≙	Defines the display which corresponds to a 0/4mA signal		0 %	
	20 mA ≙	Defines the display which corresponds to a 20mA signal		100 %	

Configuration level	Display	Function	Value range	Factory setting
5 Communication	Fieldbus	Submenu for setting the fieldbus connection		
		Fieldbus**	Submenu for setting the fieldbus connection	OFF
	Websvr	Submenu for setting the server connection		
		RS 232	Defines the type of RS 232 connection	Auto Serial
	Bdrate RS	Defines the baudrate of the RS 232 connection	38400 57600 115200	115200

*Only for activated process controllers

** Only relevant for Profibus DP, DeviceNet or Profinet versions

13 Explanation of parameters

Mode:

It is possible to choose between the operating modes **AUTO (A:)**, **MANUAL (M:)**, **MANUAL-FLEX (F)**, **TEST (T:)** and **OFF** (pause mode).

13.1 1 Service

13.1.1 Scanning the input and output signals

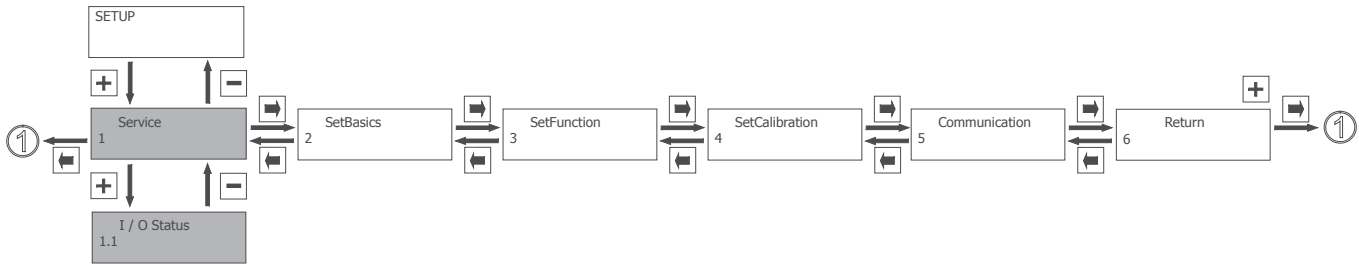

ActiveParaSet:

Displays the current active memory which is read off.

min-Pot-max:

Displays the minimum and maximum travel sensor position in percent. For perfect operation, this value must lie between 2 % and 98 %.

I w:

Displays the value of the current set value signal in mA.

I x:

Displays the value of the current actual value signal (when operated as a process controller).

I Out:

Displays the current value of the actual value output in mA.

W Proc X:

Displays the value of the current set value signal compared to the current actual value signal (when operated as a process controller).

W Pos X:

Displays the value of the current set value signal compared to the current valve position in %.

Pot Abs:

Displays the current travel sensor position (**Caution, this value may be different to the Pos x value as the valve does not make full use of the full 0-100 % range of the travel sensor**).

Valve:

Displays the current position of the internal pilot valves (● = valve open).

Proc Ctrl In:

Displays the deviation between set value and actual value (when operated as a process controller) in %.

Proc Ctrl Out:

Displays the deviation between set value and actual value (when operated as a process controller).

i If the deviation is too large, this is shown by a dot on the left-hand side or right-hand side of the display. In this case, the controller can no longer work. All parameters on the control system route must be checked.

Pos Ctrl In:

Displays the deviation between set value and actual value (when operated as a positioner) in %.

Pos Ctrl Out:

Displays the deviation between set value and actual value (when operated as a positioner).

i If the deviation is too large, this is shown by a dot on the left-hand side or right-hand side of the display. In this case, the controller can no longer work. All parameters on the control system route must be checked.

In w:x:1:2

Displays the current conditions of the digital inputs (● = Signal High).

Relay:

Displays the current position of the internal relays K1 and K2 (● = Relay switched).

13.1.2 Activating or deactivating the user access

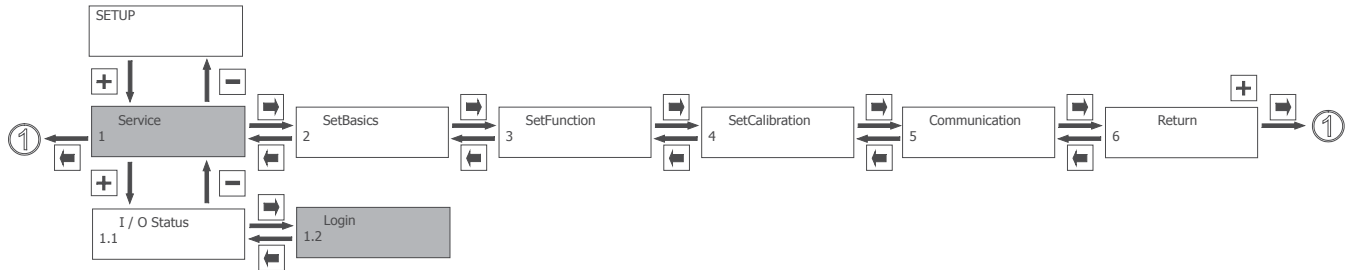

The configuration level of the GEMÜ 1436 cPos is protected in certain areas by various codes against improper changing of parameters.

All menu items are marked by symbols indicating their write and read protection.

Example:

r0w2

X-Input:	4-20 mA
	0-20 mA
	4-20 mA

The following symbols are used for this purpose:

r0: no release required for reading
w0: no release required for writing

r1: lowest priority release code 1 required for reading
w1: lowest priority release code 1 required for writing

r2: medium priority release code 2 required for reading
w2: medium priority release code 2 required for writing

r3: top priority release code 3 required for reading
w3: top priority release code 3 required for writing

The codes can be changed or activated in the following menu:

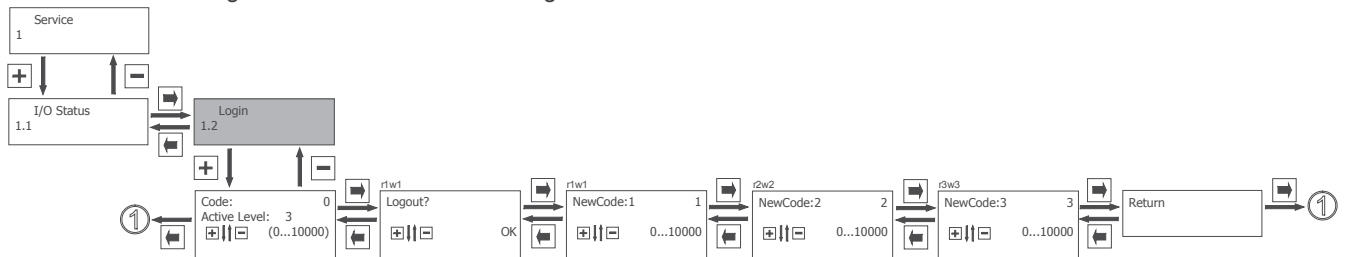

Code:

Enter code for user access. The currently released user level is displayed at Active Level.

Example:

In Active Level 0 the positioner is disabled in all three user levels.

Only the parameters marked by the symbol **r0w0** can be read and changed.

Logout:

Serves to log out of write protected and read protected areas in the menu. This function disables various menus depending on the user level activated.

User level 0 is displayed in parameter Active Level.

NewCode1:

Enter the new code for the lowest user level (user level 1) (factory setting 0).

NewCode2:

Enter the new code for the medium user level (user level 2) (factory setting 0).

NewCode3:

Enter the new code for the top user level (user level 3) (factory setting 0).



Factory setting 0 means that all three codes are assigned 0. This means that all parameter menus are released.

Example:

If user level 2 is to be disabled, user level 2 and also user level 3 must be assigned a code.



During activation or deactivation of the user levels via the RS232-interface other codes can be assigned in the same way as the direct input of codes via the GEMÜ 1436 cPos keypad. This ensures specific disabling of the use of the positioner either directly via the positioner or via the RS232-interface depending on the type of operation.

The codes for operation via the RS232-interface can only be assigned, activated or deactivated via the RS232-interface. The codes for direct operation via the GEMÜ 1436 cPos keypad can only be assigned, activated or deactivated via the keypad on the unit itself.

13.1.3 Reading out, deleting and deactivating error messages

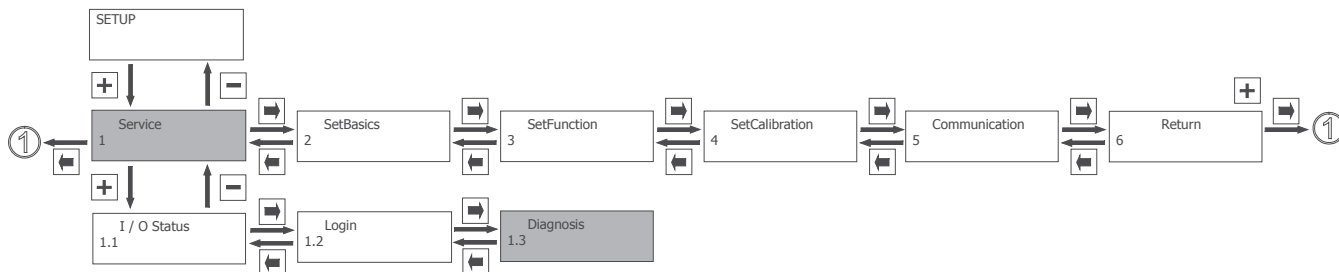

ErrorList:

The positioner stores all error messages in this menu.

hrs:

The positioner operating hours are counted here.

Warnings:

The warning messages can be masked or displayed.

The positioner continues normal operation when a warning is given. Messages are stored in the ErrorList (see chapter 14 Error messages).

Errors:

Error messages can be masked or displayed.

The positioner goes to the error mode when there is an error message and moves to the position defined under ErrorAction. Messages are stored in the ErrorList (see chapter 14 Error messages).

SensTest:

Switches the monitoring of the sensor (travel sensor) ON or OFF.

The positioner goes to the error mode when there is an error message and moves to the position defined under **ErrorAction**. Messages are stored in the ErrorList (see chapter 14 Error messages).

Enable1: Sensor monitoring activated

Disable: Sensor monitoring deactivated

ClearErrorList:

Use + to delete the positioner error list.

13.1.4 Display serial number, software version and ID and enter TAG no.

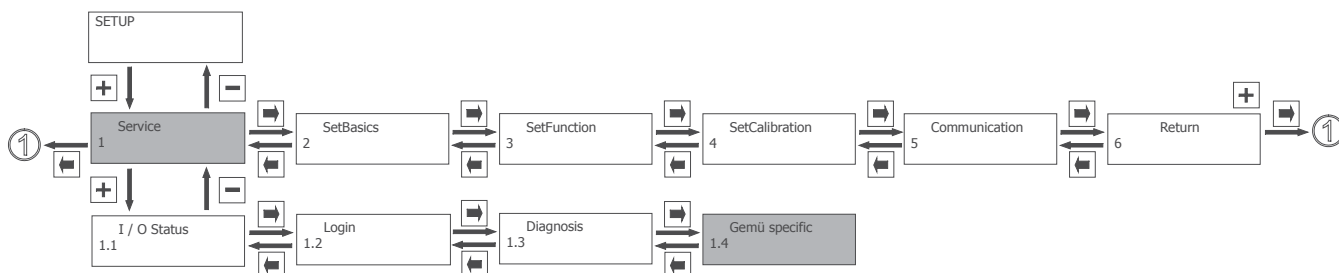

V: X.X.X.X:

Displays the current software release.

S/N:

Displays the positioner serial number.

TAG1:

An 11-digit TAG number can be entered for identification of the positioner.

TAG2:

An 11-digit TAG number can be entered for identification of the positioner.

13.2 2 SetBasics

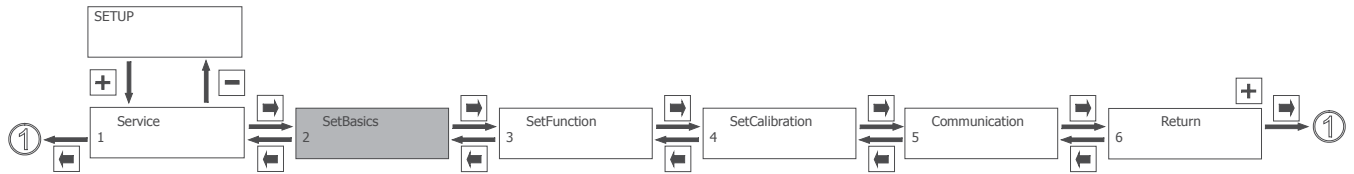

13.2.1 Definition of actual value and set value inputs

W-Input:

Defines the type of set value input signal 0-20 mA / 4-20 mA.

X-Input:

Defines the type of actual value input signal 0-20 mA / 4-20 mA.

13.2.2 Reset

Default:

Serves to reset the positioner to the factory settings. All values changed by the operator are consequently deleted. An initialisation that has already taken place will also be deleted.

Only the parameter set currently stored in the working memory is reset, however. Stored parameter sets remain unchanged (see chapter 13.3.7).

13.2.3 Initialisation

InitValve:

Automatic or manual initialisation (adaptation of the positioner to the valve) is started.

See chapter 9.2.1 - 9.2.3.

13.2.4 Making the display settings

D.Refresh:

The time for display refresh can be changed.

DLight:

The features of the display lighting can be switched between the following settings:

OnKey – Display lighting is activated by pressing a key. The display lighting remains activated after the last key is pressed for the period set using **AutoReturn**.

On – The display lighting is permanently activated.

AutoReturn:

The time for the automatic return to the working level after last activating a key can be set. This time setting is also effective for the display lighting (**DLight**).

HelpLanguage:

The help text language may be selected between D-German, GB-English and N-Norwegian.

HelpText:

The help texts that appear as a default in the second line of the display can be masked. If the help texts are masked, the key assignment is displayed.

13.3.3 SetFunction

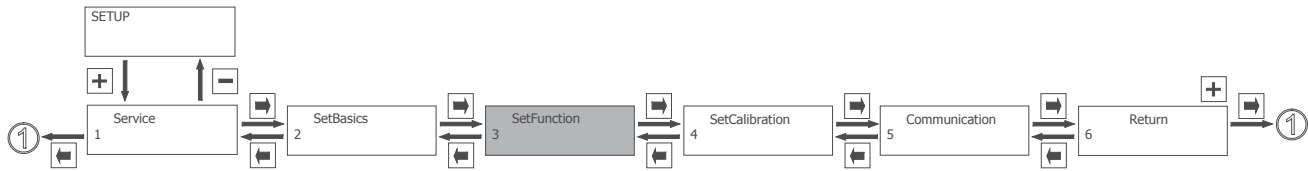

13.3.1 Setting the process controller parameters (optional)

The following menus are only available for the design with integrated process controller (PA01).

ProcCtrlMode:

Switches the process controller on or off.

ProcCtrl:

Submenu for setting process controller parameters. Only available when **ProcCtrlMode:** is **ON**.

Proc-P:

Indicates the K_P amplification of the process controller.

Proc-I:

Indicates the T_i reset time for the process controller.

Proc-D:

Indicates the K_d process controller differential component.

Proc-T:

Indicates the T_v delay time for the process controller. Only available if Proc-D > 0.

IxType:

Defines the type of actual value input filter.

OFF:

Actual value input filter deactivated.

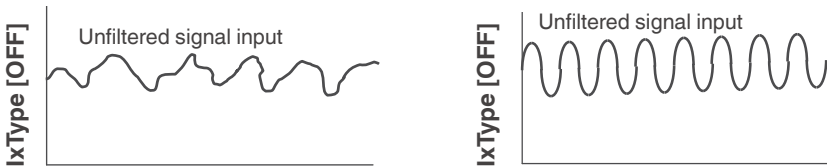

RC:

The actual value input signal is filtered via a low-pass filter.

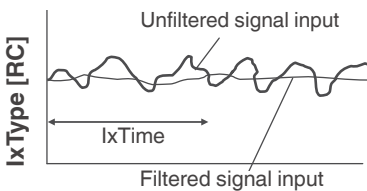

Avr:

The actual value input signal is calculated by averaging.

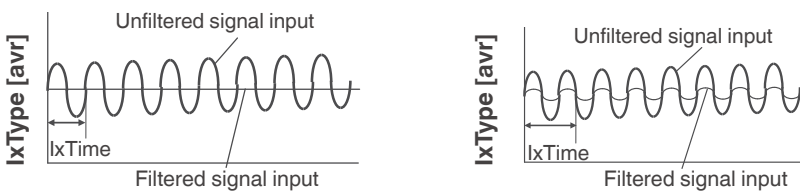

IxTime:

Defines the filter time for the actual value input.

13.3.2 Setting the positioner parameters

PosCtrl:

Provides parameters for the positioner.

Pos P:

Corresponds to the positioner's KP amplification. The optimum value is determined by the positioner during initialisation.

Pos D:

Corresponds to the positioner's D amplification.

Pos T:

Corresponds to the decay time for the positioner's D component.

MinPos:

Defines the lower position of the control range (serves as a closing limit).

MaxPos:

Defines the upper position of the control range (serves as a stroke limit).

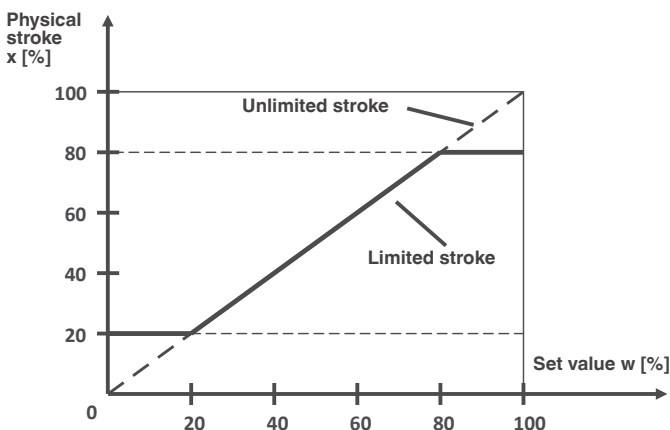

OpenTight and CloseTight:

Determines the close tight function areas (complete pressurization or ventilation of the actuator). With this function the valve can be moved into the seat using the maximum possible actuator force. The close tight function can be activated for one end or both end positions.

Example:

If the setting CloseTight 0.5 % and OpenTight 99.5 % is made, the valve closes or opens fully according to the following diagram.

The hysteresis is 1 %.

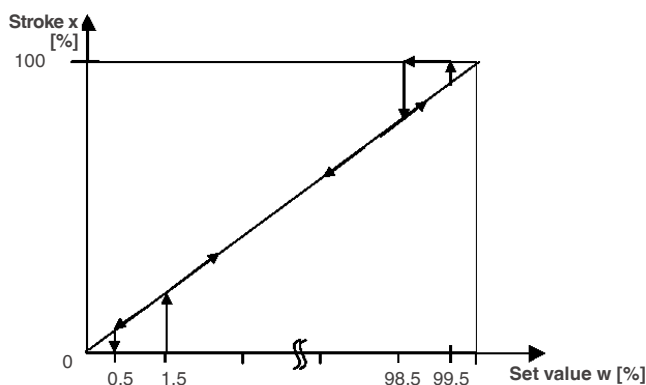

If the control characteristic curve (W function chapter 13.4.2) is changed to the values 1:25 or 1:50, the CloseTight value should be set at >2.0 (if the characteristic curve is 1:50) or >4.0 (if the characteristic curve is 1:25), in order to shut the valve fully.

13.3.3 Setting the dead zone

DeadBand:

Defines the permissible deviation – dead zone between set value and actual value.

Effects both the positioner and the process controller.



The height of the system deviation should always correspond to the requirements of the valve and the control circuit. It is recommended that you do not set a value of < 1.0% since this could (especially for actuators with discontinuous movement profiles) cause oscillating control characteristics. This could put a great deal of stress on the internal pilot valves and cause them to reach the end of their service life more quickly.

Basically: the smaller the fixed value, the higher the wear and the shorter the service life. Therefore, the value should be set only as accurate as needed.

13.3.4 Setting the optional digital input parameters

Digital Input:

Submenu for setting the digital inputs

In W:

Defines the functions of the High signal at digital input In W (connection at set value input, only effective for manual operation).

In X:

Defines the functions of the High signal at digital input In X (connection at actual value input, only effective when operating as a positioner)

In 1:

Defines the functions of the High signal at digital input 1

In 2:

Defines the functions of the High signal at digital input 2

Parameter	Function	Function at Low signal level	Function at High signal level
OFF	Digital inputs deactivated		
OFF/ON	Sets the positioner to the pause mode	OFF: Positioner in pause mode	ON: Positioner active
Safe/ON	Moves the positioner into a safe position	Safe: Positioner moves to the position defined under Error Action	ON: Positioner active
ParmSetB0	Loads parameter sets into working memory	See following table	
ParmSetB1	Loads parameter sets into working memory		
Poti / Ix	Function of the actual value output	Poti: Valve position	Ix: Process actual value

Current signal for ParmSetB1	Current signal for ParmSetB0	Memory which is read out
0	0	P1
0	1	P2
1	0	P3
1	1	P4

	Before a different parameter set can be loaded, it must first be copied to the appropriate memory (see chapter 13.3.7 CpyParamSet).
---	---

If a digital input (In W, In X, In 1 or In 2) is set to the **OFF / ON** or **Safe / ON** function and the digital signal "High" is not connected, the following messages will be displayed:

In 1 no Signal:

The positioner moves to the safe position or is stopped.

In 2 no Signal:

The positioner moves to the safe position or is stopped.

In W no Signal:

The positioner moves to the safe position or is stopped.

In X no Signal:

The positioner moves to the safe position or is stopped.

13.3.5 Setting output functions and switch points

DigitalOutput:

Defines the switch conditions for the internal outputs K1 and K2.

K1 Switch:

Defines the output contact type.

NO – make contact or NC – break contact

K1 fn:

Determines the function of output K1.

(no)	No function
(P min)	Lower than the valve position preset under AlarmMinK1
(P max)	Exceeds the valve position preset under AlarmMaxK1
(P min/max)	Lower or higher than the preset valve positions
(W min)	Lower than the set value preset under AlarmMinK1
(W max)	Exceeds the set value preset under AlarmMaxK1
(W min/max)	Lower or higher than the preset set value
(X min)	Lower than the actual value preset under AlarmMinK1
(X max)	Exceeds the actual value preset under AlarmMaxK1
(X min/max)	Lower or higher than the preset actual value
(SSE min)	Lower than the system deviation preset under AlarmMinK1
(SSE max)	Exceeds the system deviation preset under AlarmMaxK1
(SSE min/max)	Lower or higher than the preset actual value
Active	Active if the positioner is in the OFF-mode
Error	Error message
Warning	Warning message

AlarmMinK1:

Sets the switch point in % under which output K1 is switched.

AlarmMaxK1:

Sets the switch point in % over which output K1 is switched.

SSE1Time:

Determines the delay time for output K1 between error recognition and error message for a permanent system deviation.

K2 Switch:

Defines the output contact type.

NO – make contact or NC – break contact

K2 fn:

Determines the function of output K2.

(no)	No function
(P min)	Lower than the valve position preset under AlarmMinK2
(P max)	Exceeds the valve position preset under AlarmMaxK2
(P min/max)	Lower or higher than the preset valve positions
(W min)	Lower than the set value preset under AlarmMinK2
(W max)	Exceeds the set value preset under AlarmMaxK2
(W min/max)	Lower or higher than the preset set value
(X min)	Lower than the actual value preset under AlarmMinK2
(X max)	Exceeds the actual value preset under AlarmMaxK2
(X min/max)	Lower or higher than the preset actual value
(SSE min)	Lower than the system deviation preset under AlarmMinK2
(SSE max)	Exceeds the system deviation preset under AlarmMaxK2
(SSE min/max)	Lower or higher than the preset actual value
Active	Active if the positioner is in the OFF-mode
Error	Error message
Warning	Warning message

AlarmMinK2:

Sets the switch point in % under which output K2 is switched.

AlarmMaxK2:

Sets the switch point in % over which output K2 is switched

SSE2Time:

Determines the delay time for output K2 between error recognition and error message for a permanent system deviation.

Switching behaviour of outputs K1 and K2 when scanning the system deviation SSE:

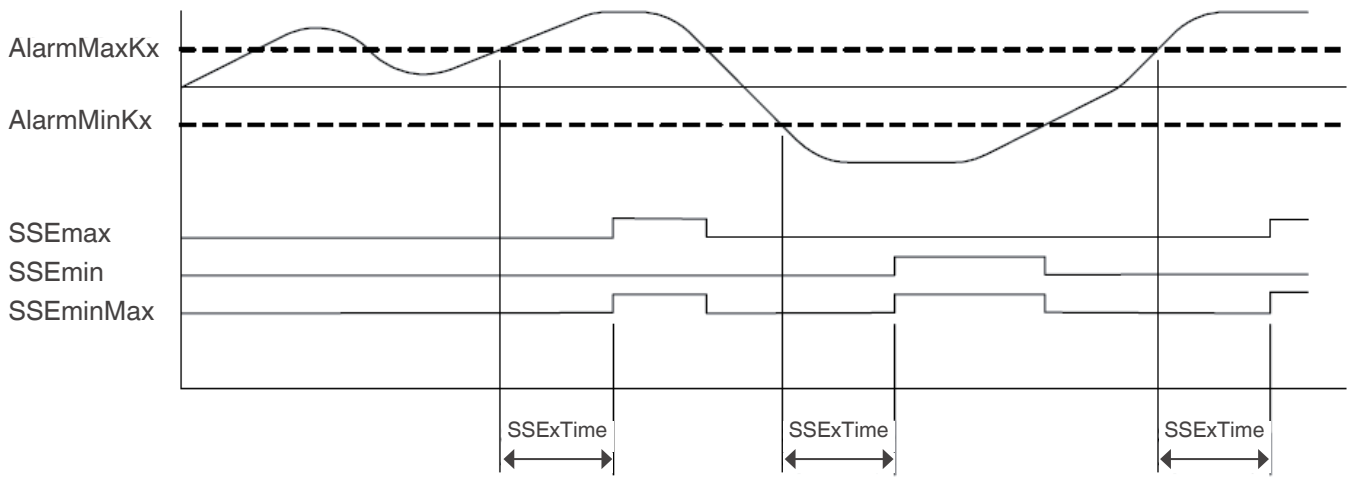

13.3.6 Setting the error time and error action

ErrorTime:

Determines the delay between error recognition and error message.

ErrorAction:

Defines the behaviour of the valve if there is an error message.

Close: Valve is vented

Open: Valve is pressurized

Hold: Valve remains at its current position.

13.3.7 Storing parameter sets

CpyParaSet:

The current positioner settings can be copied and read out in different memories.

It is not possible to load all changed control parameters into the programme memories. All possible storable parameters can be found in chapter 16.4. If a parameter cannot be stored, it is active in all memories.

(P1 <= W)	Write from W to P1
(P1 => P2)	Write from P1 to P2
(P1 <= P2)	Read from P2 to P1
(P1 => P3)	Write from P1 to P3
(P1 <= P3)	Read from P3 to P1
(P1 => P4)	Write from P1 to P4
(P1 <= P4)	Read from P4 to P1
(OFF)	Storage function deactivated
P1	Memory 1
P2	Memory 2
P3	Memory 3
P4	Memory 4
W	Factory settings

The GEMÜ 1436 cPos automatically stores all parameters in working memory P1.

13.3.8 Defining the actual value output

AnalogOut:

Defining the function of the 4-20 mA actual value output.

Poti:

The actual valve position is emitted at the 4-20 mA output.

Ix:

The actual value of the process is emitted at the 4-20 mA output (only available in the version with the integrated process controller)

13.4.4 SetCalibration

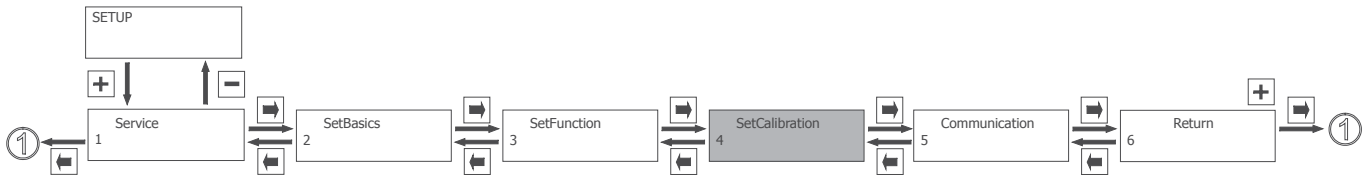

13.4.1 Determining the direction of actual value and set value

W-Direction:

Defines the direction of the set value signal (rising / falling).

X-Direction:

Defines the direction of the actual value signal (rising / falling). Only available when positioner is working as a process controller.

Working as a positioner

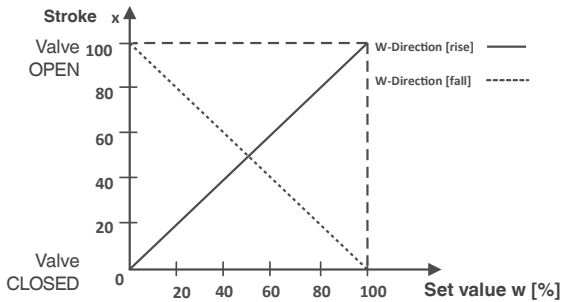

Working as a process controller

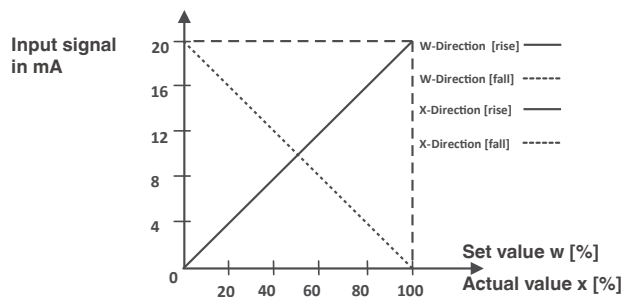

13.4.2 Defining the characteristics of the control curve

W-Function:

The characteristics of the control curve can be defined (linear/ 1:25 / 1:50 / free).

Stroke x [%]

Linear and Equal-Percentage characteristic control curves

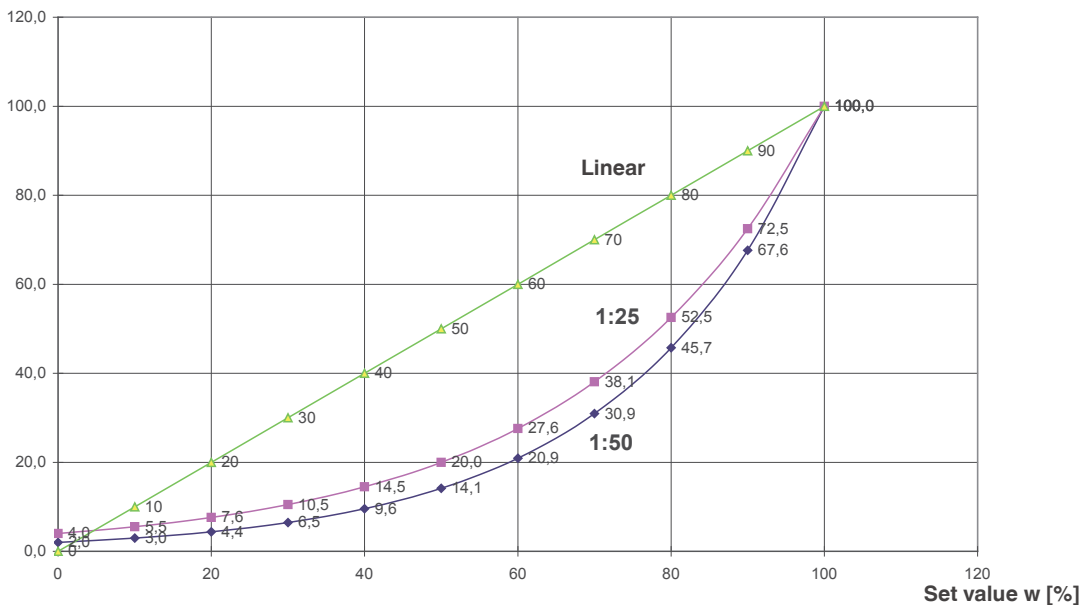

In order to be able to close the valve fully at an equal % selection of 1:25 or 1:50, the close tight function (see chapter 13.3.2) must be set to the value >2.0 (for characteristic 1:50) or >4.0 (for characteristic 1:25).

SetW-free:

Eleven calibration points on the control curve can be programmed as required.

Y-Direction:

Defines the direction of the process controller output (rising / falling). An inverted process control system can be realized.

13.4.3 Defining the direction of the travel sensor

Pot Dir:

The direction of the actual value potentiometer can be defined.

Rise: For valves with rising direction of action

- Linear actuators: Valve spindle rises when valve opens
- Quarter turn actuators: Viewed from above, shaft turns anticlockwise when valve opens

Fall: For valves with falling direction of action

- Linear actuators: Valve spindle falls when valve opens
- Quarter turn actuators: Viewed from above, shaft turns clockwise when valve opens

In combination with the respective direction of the valve, these settings mean that the valve opens when the signal rises and the display and output values have the same direction of action.

If valves are operated in reverse (rising signal closes valve), the **W-Direction** parameter must be reset, otherwise the display and the output signal would be inversed.

13.4.4 Defining the actual value output signal



If a higher value is entered for OutMinPos than for OutMaxPos, the direction of the output signal is inverted.

OutMinPos:

Defines the valve position at which an actual value signal of 4 mA is emitted at the output.

OutMaxPos:

Defines the valve position at which an actual value signal of 20 mA is emitted at the output.

13.4.5 Determining switch points for error monitoring

I Min W:

Defines the point below which the set value signal activates an error message

I Max W:

Defines the point above which the set value signal activates an error message.

I Min X:

Defines the point below which the actual value signal activates an error message.

I Max X:

Defines the point above which the actual value signal activates an error message.

13.4.6 Scaling the actual value and set value display

Scaling:

Submenu for scaling the actual value and set value display.

Scaling:

Defines whether the actual and set value display is to be displayed as scaled variable or in percent.

ON:display as scaled variable; OFF: display in percent

Decimalpoint:

Determines the number of digits displayed after the decimal point.

4 mA ⇌:

Defines the value which is displayed when there is a 0/4mA signal.

20 mA ⇌:

Defines the value which is displayed when there is a 20mA signal.

Possible setting values for the freely scalable actual and set value inputs:

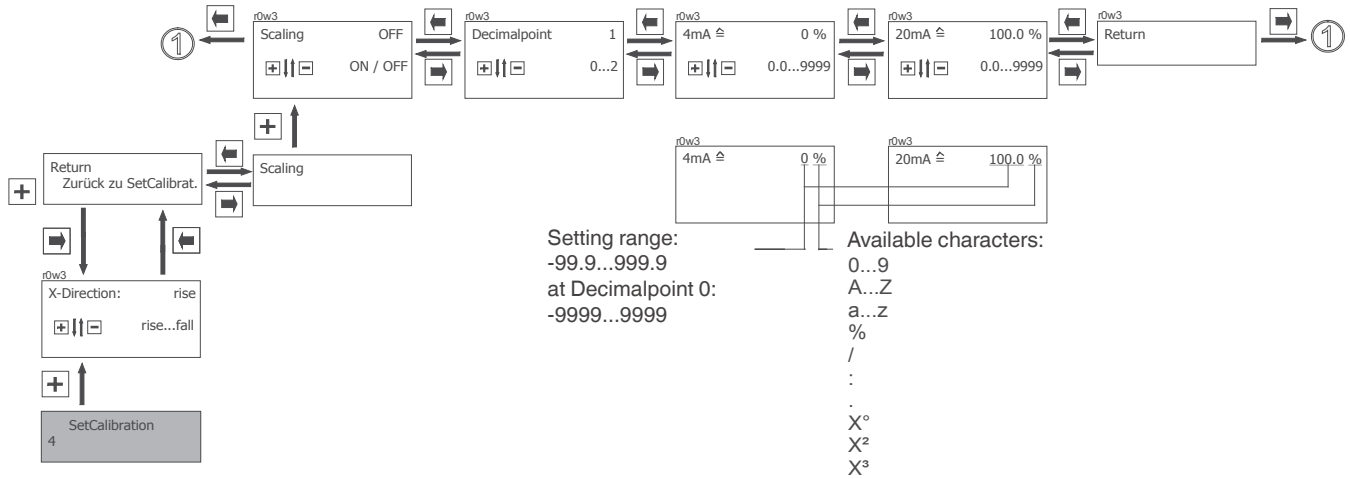

Display when Scaling OFF is set:

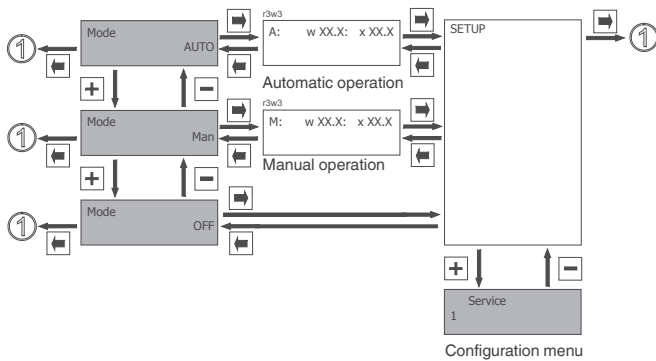

Display when Scaling ON (e.g. mbar) is set:

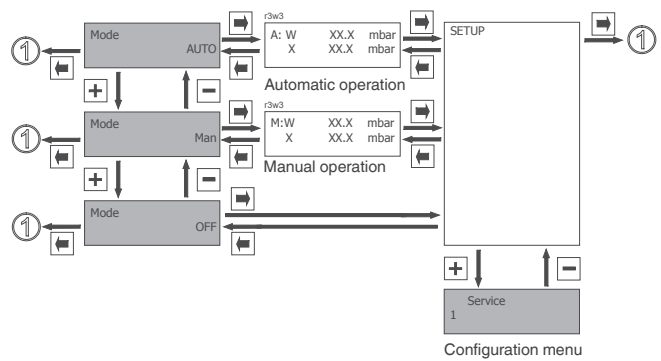

5 Communication

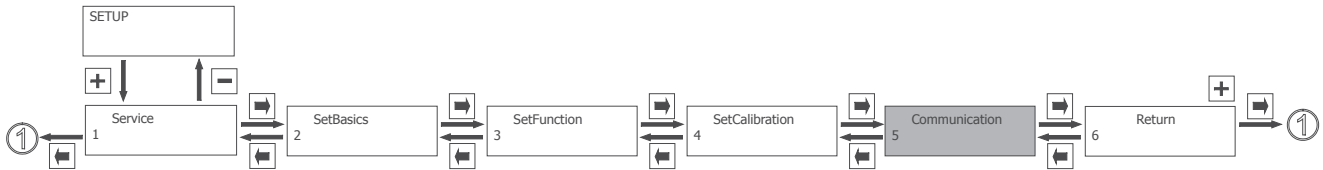

13.4.7 Setting the fieldbus parameters

Fieldbus:

Only available in fieldbus version
For details see separate operating instructions.

13.4.8 Setting the communication parameters

For details on how to use the GEMÜ e.^{SY}-com interface and operating the browser see separate operating instructions.

WebServer:

Submenu for setting the communication parameters

RS 232:

Defines the type of RS 232 connection

Auto	If you use a connection with a PC/laptop or industrial modem
Serial	If you use a connection with a PC/laptop

Bdrate RS:

Defines the baudrate of the serial connection.

Bdrate RS	38400 baud
	57600 baud
	115200 baud (Werkseinstellung)

14 Error messages

No.	Error text	Description	Condition for the occurrence of the error	Error cause
000	NO ERROR	There are no errors		
010	lw < 4 mA Error	The set value signal is lower than 4mA	The positioner is in automatic mode	A cable break at the set value input
011	lw > 20 mA Error	The set value signal is higher than 20mA	The positioner is in automatic mode	The set value signal is higher than 20mA
012	lx < 4 mA Error	The actual value signal is lower than 4mA	The process controller is active	A cable break at the actual value input
013	lx > 20 mA Error	The actual value signal is higher than 20mA	The process controller is active	The actual value signal is higher than 20mA
020	Pot wrong dir Error	The potentiometer has recognised the wrong control function during initialisation.	Parameter "CtrlFn" is set to AUTO and a valve with control function 3 is recognised, from which the actuator has moved in the wrong direction. Parameter "CtrlFn" is set for a fixed control function. This set control function is not in accordance with the control function determined during initialisation.	The pneumatic connections for "CLOSED" and "OPEN" on the valve have been switched or the parameter "Pot Dir" is set on "fall". The wrong control function is set.
021	Wrong function Error	An incorrect control function was recognised during automatic initialisation.	Parameter "CtrlFn" is set for a fixed control function. This set control function is not in accordance with the control function determined during initialisation.	The wrong control function is set in the "CtrlFn" parameter. If the parameter is set to AUTO, the 1436 cPos determines the corresponding control function and leaves it there (this does not apply for control function 8 – carry out manual initialisation in this case, or set the parameter "CtrlFn" to "DNO").
022	Pneumatic Error Error	During automatic initialisation of the valve a pneumatic error was detected.	<ul style="list-style-type: none"> ● Control air failed ● The minimum stroke was undershot ● End positions cannot be reached ● Leakage in the system 	Check the stroke of the pneumatic system. Check leakage and end positions. Observe minimum actuator control pressure.
023	Leakage Error	During automatic initialisation of the valve leakage was detected.	The positioner is in initialisation mode.	Check the pneumatic system for leakage and carry out initialisation again.
030	Air missing Warning	A failure of the compressed air was discovered.	The 1436 cPos tries to change the valve position, but it changes in the wrong direction. Warning: Dependent on the positioner's set value reaction time, the error may be acknowledged in the meantime. It then recurs.	<ul style="list-style-type: none"> ● Leakage in the system ● No compressed air ● Failure of the internal pilot valves ● Valve mechanically locked
060	TrvlSensErr Error	A cable break, short-circuit or exceeded range in the travel sensor connection or in the travel sensor was detected.		<ul style="list-style-type: none"> ● Wrong mounting kit ● Incorrect mounting ● Faulty travel sensor ● Faulty travel sensor connection
200	Error EEPROM Error	An error has occurred with the external EEPROM	This error is generated if the calibration data from the IO card EEPROM could not be read.	The error is only displayed for 1 minute when the controller is switched on and then disappears automatically. The automatic control system still operates correctly, but the controller must be sent to GEMÜ for examination.
201	Intern.Error Info	An error has occurred with an EEPROM.	This information is displayed if an error has occurred while attempting to access an EEPROM.	The message is generated if an EEPROM could not be read from or written to. Send the controller to GEMÜ for repair.

	Error text	Description	Condition for the occurrence of the error	Error cause
	In 1 no Signal	No signal at digital input In 1	Parameter In 1 is set to OFF / ON or Safe / ON	Connect signal to digital input In 1
	In 2 no Signal	No signal at digital input In 2	Parameter In 2 is set to OFF / ON or Safe / ON	Connect signal to digital input In 2
	In W no Signal	No signal at digital input In W	Parameter In W is set to OFF / ON or Safe / ON	Connect signal to digital input In W
	In X no Signal	No signal at digital input In X	Parameter In X is set to OFF / ON or Safe / ON	Connect signal to digital input In X

All error messages can be read in the menu item ErrorList (**1 Service / 1.3 Diagnosis**).

The menu item ClearErrorList (**1 Service / 1.3 Diagnosis**) can be used to clear the internal error memory.

Occurrence of the error in the "NoInIt" menu

The error message is displayed in the "NoInIt" menu. Pressing the **+** or **-** key switches off the error display and "NoInIt" and the current valve position are displayed. The valve can be moved/operated using the **+** and **-** keys.

The error message is superimposed again when the movement is finished. To complete the action the menu must be exited by pressing the **←** oder **→** key.

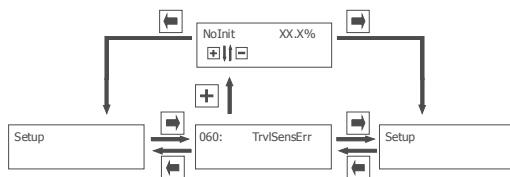

15 Quick guide

15.1 Changing the set value signal and actual value signal

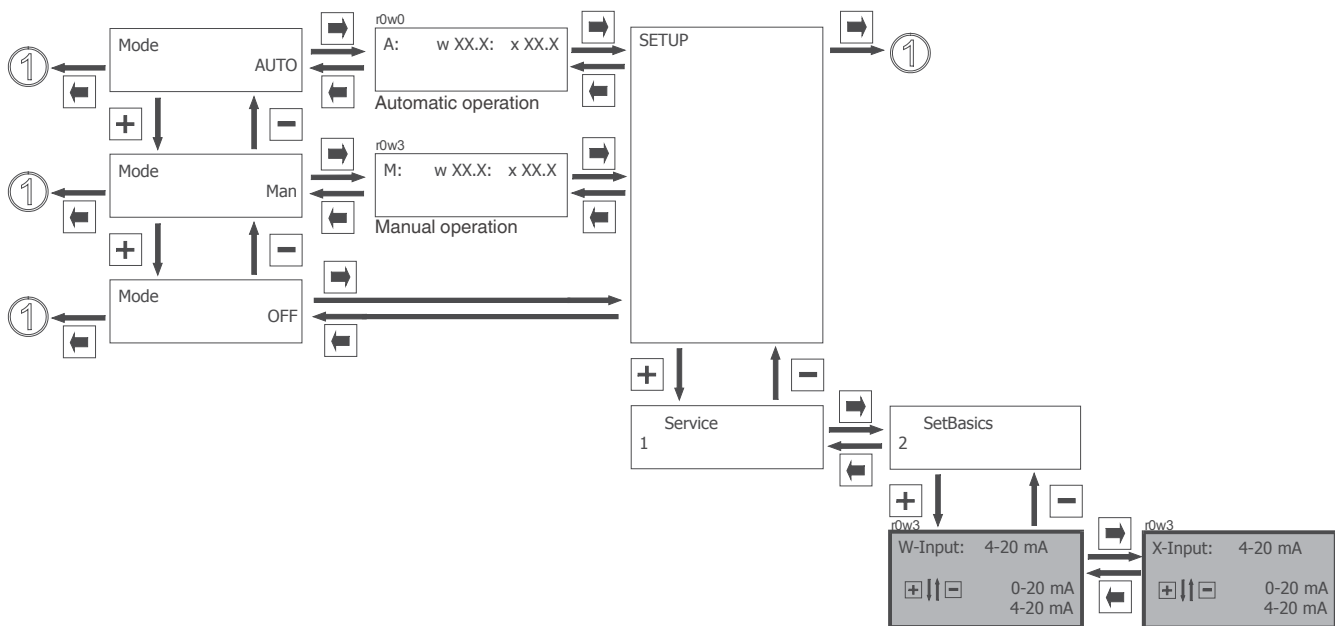

15.2 Switching the process controller on or off (optional)

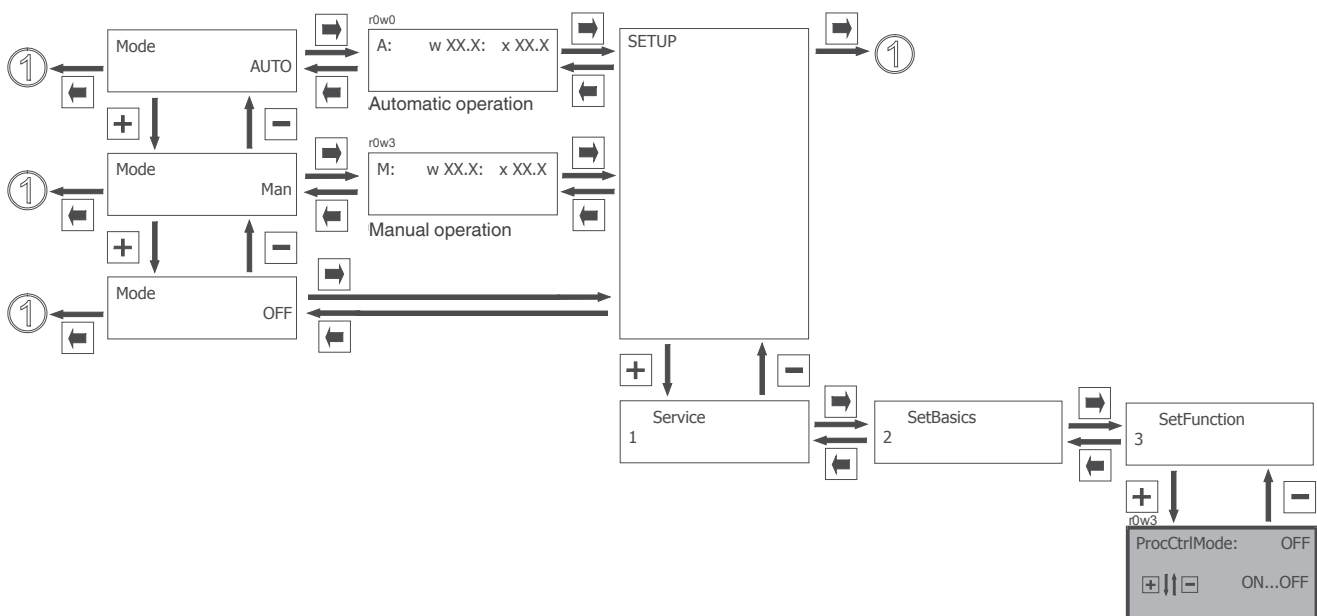

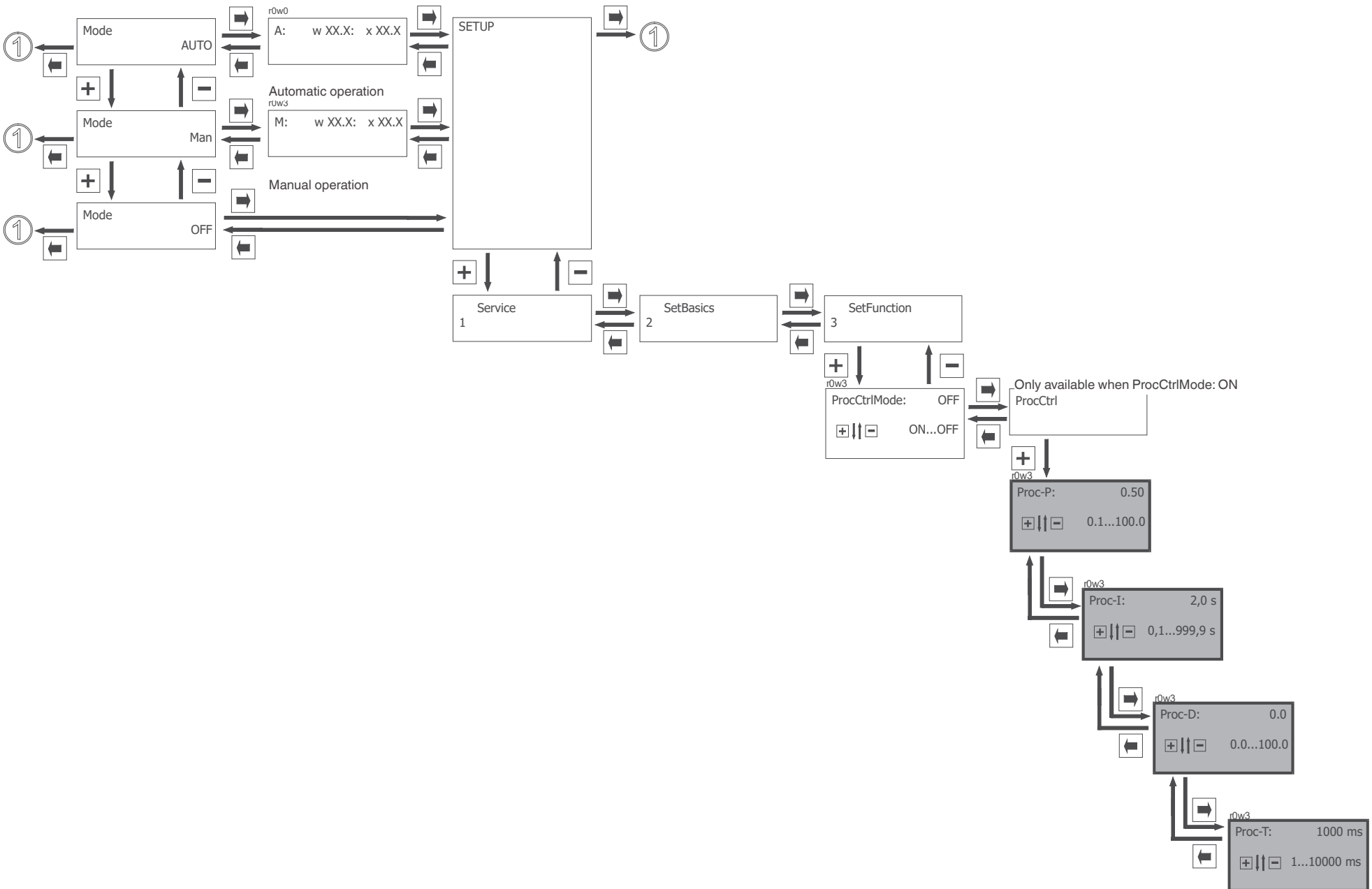

16 General information regarding control engineering

16.1 The control circuit

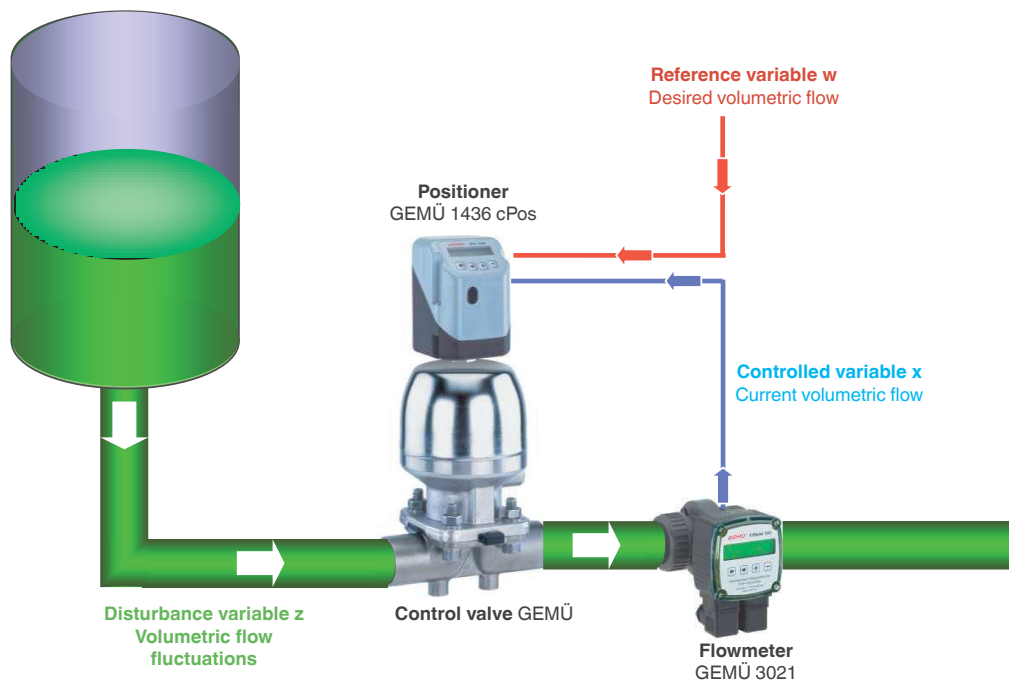

16.2 Control engineering terminology

Reference variable (set value) w:

The input variable (set value) for the control circuit. The controlled variable x should follow it with a pre-determined dependency.

Controlled variable (actual value) x:

The volumetric flow currently measured.

Control difference xd:

The difference between reference variable w and controlled variable x, $x_d = w - x$

Manipulated variable y:

Input variable for the controlled system. The process controller guidance to the positioner regarding the position in which the triggered control valve must be driven in order to achieve the desired volumetric flow.

Disturbance variable z:

An external variable that influences the controlled system that normally cannot be influenced (e.g. volume flow fluctuations).

16.3 Control parameters

Explanation of parameters of GEMÜ 1436 cPos:

Proc P: K_p

Proc I: T_n

Proc D: K_D

Proc T: T_v

Proportional band X_p :

The proportional band tells us the extent to which the controlled variable x changes when the manipulated variable y is adjusted.

X_p can be used to adapt the controller amplification to the controlled system.

If a small proportional band is selected, it has a large manipulated variable y (e.g. 20mA) as a result, i.e. the

controller reacts more swiftly and harder with a small proportional band. If a too small proportional band is chosen, this leads to oscillation of the control circuit.

Proportional action factor K_p :

Instead of the description proportional band, the expression proportional-action factor K_p is used frequently.

Conversion of X_p to K_p is:

$$X_p = 100[\%] / K_p$$

or

$$K_p = 100[\%] / X_p$$

The K_p value tells us to what degree the controlled variable x changes if the manipulated variable y is adjusted.

$$K_p = \Delta x / \Delta y = x_2 - x_1 / y_2 - y_1$$

In order to obtain a unit-independent relationship in the equation above, x and y must be divided by their respective maximum values (100 %).

In this case, a high K_p value results in smaller deviation. However, if the K_p value is set too high, it leads to an increased tendency for the control circuit to oscillate.

Derivative action time T_v :

It is used to set the intensity of the D component.

Differential component (D component):

For an inverse controller (heating) the D component has the following effects:

- If the controlled variable is reduced due to a disturbance in the controlled system, the D component counteracts the change by creating a positive regulation ratio.
- If the controlled variable increases due to a disturbance in the controlled system, the D component counteracts this change by creating a negative regulation ratio.

The higher the derivative action time T_v is set, the stronger the dampening reaction.

Integral-action component (I component) K_i :

The I component K_i changes the controller regulation ratio continuously until the actual value reaches the set value. The regulation ratio will be integrated upwards or downwards as long as a system deviation exists. The influence of the I component will become larger the longer a system deviation exists. The shorter the reset time T_n and the larger the system deviation, the stronger (faster) the effect of the I component. The I component hinders a constant system deviation.

Reset time T_n :

The reset time T_n determines the duration how long a system deviation is adjusted. If a high value is preset for the reset time T_n this means a small influence of the I component and vice-versa. During the reset time T_n the controlled variable change caused by the P component is added again. Thus there is a fixed relationship between the P component and the I component. If the P component is thus changed, the time response changes too if the T_n value remains constant.

$$K_i = 1 / T_n$$

16.4 Adaptation of the controller to the controlled system

Optimisation of the controller:

In order to achieve good behaviour of the control circuit it is necessary to adapt the controller to the process. Good valve behaviour, for instance, can be quick adjustment of maximum power for pre-shooting or non-overshooting-free adjustment of maximum power if the adjustment of power takes longer. The optimum adjustment parameters must be determined "manually" by trial and error through experimentation or rule of thumb.

Explanation of parameters of GEMÜ 1436 cPos:

Proc P: K_P
 Proc I: T_n
 Proc D: K_D
 Proc T: T_v

Interpretation of the controller parameters according to Ziegler-Nichols:

The following process is intended to help to adapt the controller to the controlled system (however this process can only be implemented on controlled systems where it is possible to let the controlled variable oscillate of its own accord).

- Set the values for K_P (Proc P) and T_v (Proc T) to their minimum and the T_n (Proc I) value to 0 (this leads to the smallest possible effect of the controller).
- Enter the desired set value manually in manual mode.
- Slowly increase K_P (Proc P) (decrease X_p), until the controlled variable starts to oscillate harmoniously. Ideally the control circuit should be stimulated to oscillate by erratic set value changes during the K_P adjustment.
- Note the K_P value thus obtained as a critical proportional action factor $K_{p,krit}$.
- Following this, determine the duration of an oscillation as T_{krit} . If possible, use a stopwatch to measure several oscillations and use the arithmetic mean as T_{krit} .
- Use the values thus determined for $K_{p,krit}$ and T_{krit} to calculate the missing K_P , T_n and T_v parameters according to the following table.

	$K_P = \text{Proc P}$	$T_n = \text{Proc I}$	Proc D	$T_v = \text{Proc T}$
P	$0.50 \times K_{p,krit}$	0	0	0
PI	$0.45 \times K_{p,krit}$	$0.85 \times T_{krit}$	0	0
PID	$0.59 \times K_{p,krit}$	$0.50 \times T_{krit}$	$0.59 \times K_{p,krit}$	$0.12 \times T_{krit}$

- If necessary, re-adjust the K_P and T_n values a little until the control system shows satisfactory behaviour

16.5 Differential equation for the GEMÜ 1436 cPos

$$y = \text{ProcP} * \left[x_d + \frac{1}{\text{ProcI}} * \int x_d dt \right] + \text{ProcD} * \left[\frac{dx_d}{dt} - \text{ProcTv} * \frac{dy}{dt} \right]$$

16.6 Effects of the control parameters on the control system

Proc P:	
Larger:	The controller controls faster, however it tends to oscillate and controls less accurately. The set value is achieved in larger steps by increasing the manipulated variable
Smaller:	The controller controls more slowly as the set value is achieved in smaller steps by decreasing the manipulated variable. Control is more precise.

Proc I:	
Larger:	The controller reacts more slowly to actual value changes. Proc I should be increased for actual value sensors with relatively slow output signals.
Smaller:	The controller reacts faster to actual value changes.

Proc D:	
Larger:	Slows down the manipulated variable y when moving to the set value. Control is slower.
Smaller:	Set value is achieved faster.

Proc T:	
Larger:	The system deviation has a longer effect although set value = actual value

16.7 Control characteristics and transitory responses

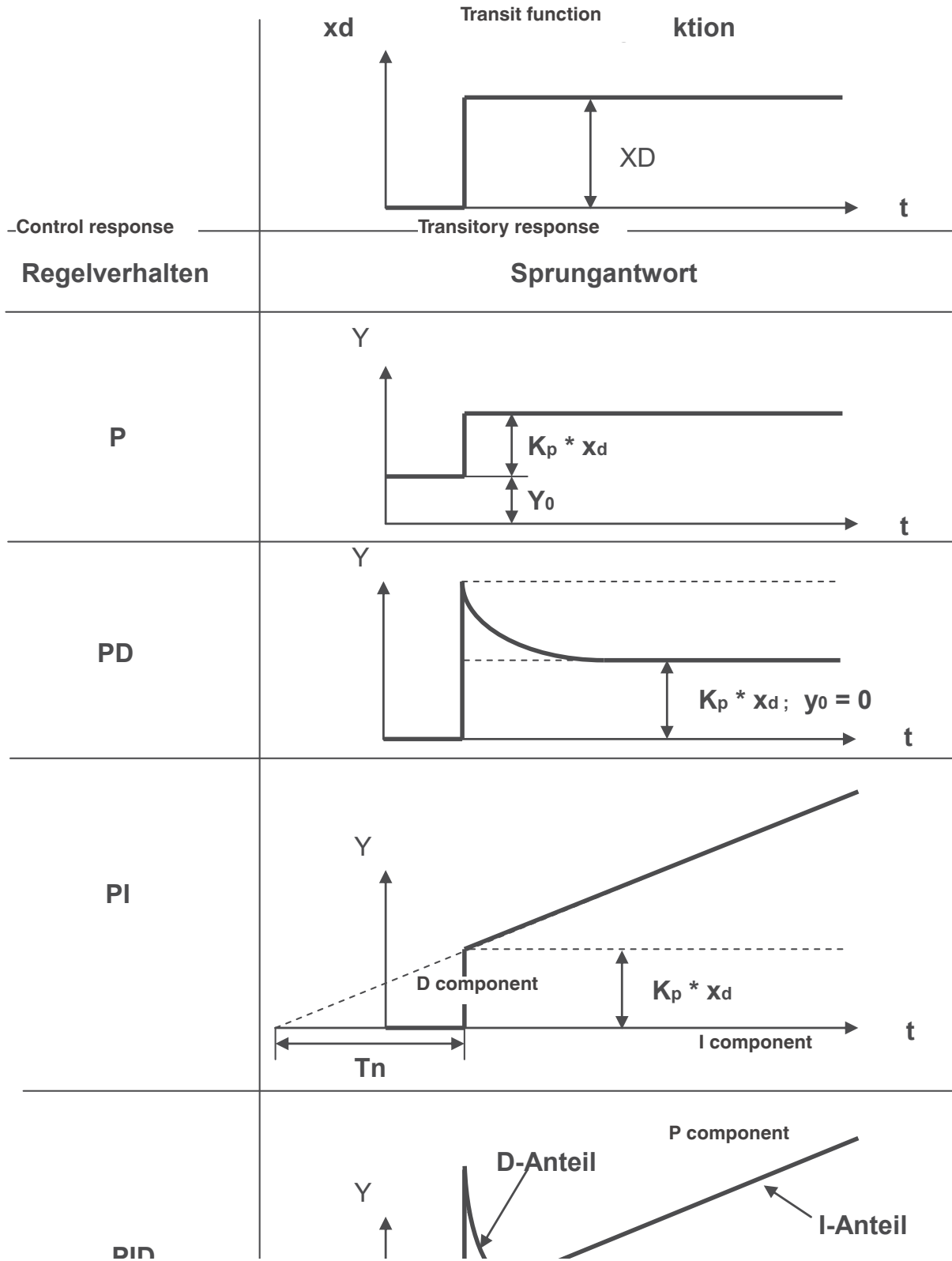

17 Table for changes to the factory settings

17.1 Changed control parameters

Fields marked by X cannot be written into the individual memories but are active for all memories.

Configuration level	Display	Function	P1	P2	P3	P4	Factory settings
1 Service	New Code: 1	Release lowest user level		X	X	X	0
	New Code: 2	Release medium user level		X	X	X	0
	New Code: 3	Release top user level		X	X	X	0
	Warnings	Display warnings					ON
	Errors	Display errors					ON
	SensTest	Activate sensor test					Disable
	TAG1	Enter TAG no. 1		X	X	X	
	TAG2	Enter TAG no. 2		X	X	X	

Configuration level	Display	Function	P1	P2	P3	P4	Factory settings
2 SetBasics	W-Input	Type of set value signal					4-20 mA
	X-Input	Type of actual value signal					4-20 mA p
	CalPointQty	Quantity of calibration points when initialising					9
	D.Refresh	Time for display refresh		X	X	X	0.1s
	DLight	Setting the display lighting					OnKey
	AutoReturn	Time for an automatic return to the working level					5min
	HelpLanguage	Text language					D
	HelpText	Display the help text					ON

Configuration level	Display	Function	P1	P2	P3	P4	Factory settings
3 SetFunction	ProcCtrlMode	Switch process controller on or off					OFF
	Proc-P	KP amplification of the process controller					0.5
	Proc-I	KI reset time for the process controller					2.0s
	Proc-D	KD component of the process controller					0.0
	Proc-T	Process controller delay time					1000 ms
	IxType	Type of actual value filter					OFF
	IxTime	Filter time for actual value input					0.10 s
	Pos P	P amplification of the positioner					1.0
	Pos D	D amplification of the positioner					0.0
	Pos T	Decay time of the D component of the positioner					100 ms
	MinPos	Lower position for stroke limitation as a control range					0.0 %
	MaxPos	Upper position for stroke limitation as a control range					100 %
	CloseTight	Lower close tight function					0 %
	OpenTight	Upper close tight function					100 %
	DeadBand	Permissible system deviation					1,0 %, K-no. 2442: 2,0 %, K-no. 2443: 5,0 %
	In W	Determines the function of the digital input "In W"		X	X	X	OFF
	In X	Determines the function of the digital input "In X"		X	X	X	OFF
	In 1	Determines the function of the digital input "In 1"		X	X	X	OFF
	In 2	Determines the function of the digital input "In 2"		X	X	X	OFF
	K1 Switch	Defines the type of output K1					NO
K1 Fn	Determines the function of output K1					no	

Configuration level	Display	Function	P1	P2	P3	P4	Factory settings
	AlarmMaxK1	Switch point that switches after K1 is exceeded					10.0 %
	AlarmMinK1	Switch point that switches after K1 is undershot					90.0 %
	SSE1Time	Defines the delay time between error recognition and error message to K1					5.0s
	K2 Switch	Defines the type of output K2					NO
	K2 Fn	Determines the function of output K2					no
	AlarmMaxK2	Switch point that switches after K2 is exceeded					10.0 %
	AlarmMinK2	Switch point that switches after K2 is undershot					90.0 %
	SSE2Time	Defines the delay time between error recognition and error message to K2					5.0s
	Error Time	Determines the delay between error recognition and error message					0.2s
	ErrorAction	Function of the process valve if there is an error message					Close
	AnalogOut	Defines the function of the actual value output					Poti

Configuration level	Display	Function	P1	P2	P3	P4	Factory settings
4 SetCalibration	X-Direction	Determines the direction of the actual value signal (rising/falling)					rise
	W-Direction	Determines the direction of the set value signal (rising/falling)					rise
	W-Function	The control curve is defined					lin.
	Y-Direction	Determines the direction of the process controller output (rising/falling)					rise
	PotDir	Defines the direction of the actual value potentiometer of the valve					rise
	OutMinPos	Actual value output at 0/4 mA					0.0 %
	OutMaxPos	Actual value output at 20 mA					100.0 %
	I Min W	Switch-off limit for cable break recognition of the set value					3.5 mA
	I Max W	Switch-off limit for excess current recognition of the set value					20.5 mA
	I Min X	Switch-off limit for cable break recognition of the actual value					3.5 mA
	I Max X	Switch-off limit for excess current recognition of the actual value					20.5 mA
	Scaling	Switches the scaled display on					OFF
	Decimalpoint	Determines the number of digits displayed after the decimal point					1
	4 mA \triangle	Defines the display which corresponds to a 0/4mA signal					0 %
	20 mA \triangle	Defines the display which corresponds to a 20mA signal					100 %

Configuration level	Display	Function	P1	P2	P3	P4	Factory settings
5 Communication	Fieldbus	Submenu for setting the fieldbus address if available		X	X	X	OFF

17.2 Set values for the freely programmable characteristic curve

Configuration level	Display	Characteristic curve point	P1	P2	P3	P4	Factory settings
4 SetCalibration	Set W-free	0 %					0 %
		10 %					10 %
		20 %					20 %
		30 %					30 %
		40 %					40 %
		50 %					50 %
		60 %					60 %
		70 %					70 %
		80 %					80 %
		90 %					90 %
		100 %					100 %

18 Disposal



- All parts must be disposed of according to relevant local or national disposal regulations / environmental protection laws.
- Pay attention to adhered residual material and gas diffusion from penetrated media.

19 Returns

- Clean the positioner.
- Request a goods return declaration form from GEMÜ.
- Returns must be made with a completed declaration of return.

If not completed, GEMÜ cannot process

x credits or

x repair work

but will dispose of the goods at the operator's expense.



Note for returns:

Legal regulations for the protection of the environment and personnel require that the completed and signed goods return declaration is included with the dispatch documents. Returned goods can be processed only when this declaration is completed.

20 Information



Note on staff training:

Please contact us at the address on the last page for staff training information.

Should there be any doubts or misunderstandings in the preceding text, the German version of this document is the authoritative document

21 Technical data

General information

Protection class to EN 60529	IP 65
Weight	approx. 600 g
Dimensions L x W x H	See dimensional drawing
Installation position	Optional

Directives

EMC Directive	2014/30/EU
---------------	------------

Particulars

Fail safe function in case of compressed air or power supply failure (see table on page 59)

Operating conditions

Ambient temperature	0 ... +60 °C
Storage temperature	0 ... +60 °C
Control medium	Quality classes to DIN ISO 8573-1: 2010
Dust content	≤ 10 mg/m ³ /particle size ≤ 40 µm (class 7)
Pressure dew point	≤ +3 °C (class 4)
Oil concentration	≤ 5 mg/m ³ (class 4)
Air supply	1.5 ... 7 bar
Air consumption	0 l/min (when idle)
Air output	150 / 200 / 300 l/min depending on version

Materials

Housing cover	PSU
Housing base	PP 30

Travel sensor integrated in directly mounted version

Linear design

Stroke	0-30 / 0-50 / 0-75 mm
Resistance R	3 / 5 / 5 kΩ
Minimum stroke	≤ 8 % of the travel length ≥ 1 % of the travel length

Quarter turn design

Angle of rotation	0-93°
Resistance R	3 kΩ

Controller data

Positioner

System deviation	1 % (factory setting) ≥ 0,1 % (can be set) ≤ 2,0 % (factory setting, K-no. 2442) ≤ 5,0 % (factory setting, K-no. 2443)
PD parameters	adjustable
Initialisation	automatic or manual

Process controller can be connected (version PA 01)

Controller type	continuous controller
PID parameters	adjustable

Parameterisation at the device: Menu selection
context sensitive or help texts
at the PC: Internet MS Internet Explorer

Operating and display elements

Text display	Alphanumeric, 2-line display with 16 digits each with background light
LED front, top	Status, for Profibus-DP and DeviceNet and Profinet option
LED front, bottom	Status, for Profinet option
Keys	4 membrane protected fascia keys

Interfaces

RS232	Parameterisation via web browser
Profibus DP	Parameterisation / process data
Transmission rates	9.6k / 19.2k / 45.45k / 93.75k / 500k 1.5M / 3M / 6 M / 12 M Baud
DeviceNet	Parameterisation / process data
Transmission rates	125k / 250k / 500k Baud
Profibus DP	Parameterisation / process data
Transmission rates	100 M Baud

Electrical data

Power supply

Power supply	U _v = 24 V DC +10 % / -5 %
Duty cycle	continuous duty
Reverse battery protection	yes
Current consumption	for flow rate code 01, 02 I _{typ} = 140 mA (@ 24 V DC) for flow rate code 03 I _{typ} = 175 mA (@ 24 V DC)

Input signals

Analogue inputs

Set value / actual value	0/4 - 20 mA (selectable)
Input resistance	120 Ω (for device version code PA01)
Accuracy / Linearity	± 0.3 % of full flow
Temperature drift	± 0.3 % of full flow
Resolution	12 bit
Reverse battery protection	yes
Overload proof	yes (up to ± 24 V DC)

Travel sensor input*

External travel sensor input	0...10 V DC (for travel length code S01)
Supply voltage output	UP+ typ. 10 V DC
Short-circuit proof:	yes
Resistance range ext. potentiometer	1...10 kΩ
Input voltage range	0... UP+
Accuracy / Linearity	± 0.3 % of full flow
Temperature drift	± 0.3 % of full flow
Resolution	12 bit
Overload proof	yes (up to ± 24 V DC)

* Travel sensor input galvanically isolated from supply voltage, not galvanically isolated from the set value/actual value inputs and actual value output.

Digital inputs

Function	selectable via software (DigIn 1; DigIn2; DigInW; DigInX) (Reference: GND X1:3)
Voltage	24 V DC
Logic level "1"	>14 V DC
Logic level "0"	< 8 V DC
Input current	typ. 2.5 mA DC (at 24 V DC)

Output signals

Analogue outputs

Actual value	4...20 mA
Output type	active
Accuracy	± 1 % of full flow
Temperature drift	±0.5 % of full flow
Load resistor	600 Ω
Resolution	12 bit
Overload proof	yes (up to ± 24 V DC)
Short-circuit proof	yes

Digital outputs

Switching output K1/K2	selectable via software
Type of contact	PNP
Switching voltage	Power supply
Switching current	0.5 A
Drop voltage	max. 2.5 V DC at 0.5 A
Overload proof	yes (up to ± 24 V DC)
Short-circuit proof	yes
Pull down resistance	120 kΩ

Functions

- Positioner + process controller combined and synchronized with each other
- Automatic or manual optimizing initialisation
- Multiple point calibration for optimized valve control
- Diagnostics, alarm messages
- Operation possible when controller is active
- 3 parameter sets can be saved and reloaded
- 3 user levels (access authorization)
- Operating hours counter, event list (for details see operating instructions)
- Digital inputs (option) for variable function control for automation

22 Order data

Note

The GEMÜ 1436 cPos positioner can be directly or remotely mounted to linear or quarter turn actuators

Direct mounting

For direct mounting the following components are required which must be ordered separately:

Linear actuators		Quarter turn actuators	
Positioner GEMÜ 1436...030/050/075 See order data - Positioner (direct mounting)	(A)	Positioner GEMÜ 1436...090 See order data - Positioner (direct mounting)	(A)
Mounting kit GEMÜ 1436 S01 Z... See order data - Mounting kit for linear actuators	(B)	Mounting kit GEMÜ 1436 PTAZ... See order data - Mounting kit for quarter turn actuators	(D)
Connection kit GEMÜ 1436 S02 Z... See order data - Connection kit	(C)	Connection kit GEMÜ 1436 S02 Z... See order data - Connection kit	(C)

Direct mounting to
linear actuator

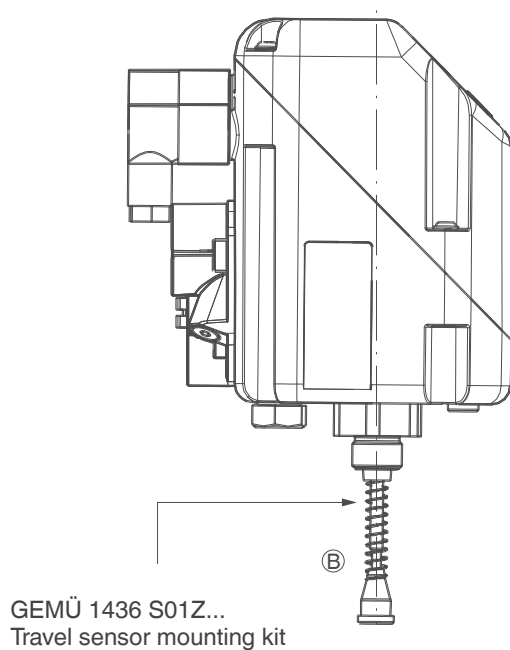

Direct mounting to
quarter turn actuator

(A)
GEMÜ 1436 cPos
Positioner

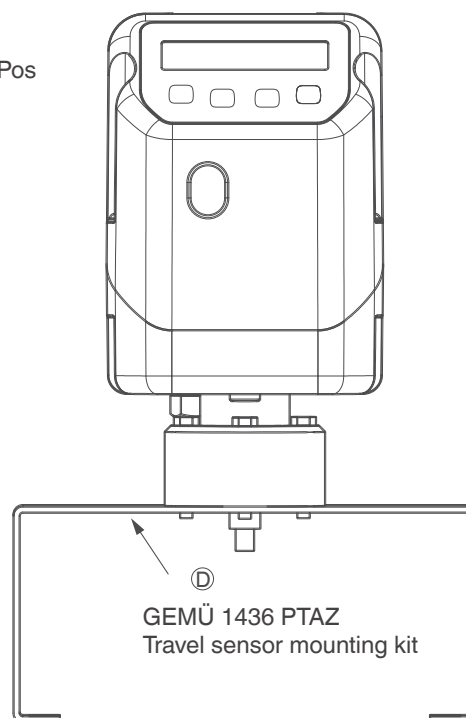

GEMÜ 1436 S02Z
Connection kit

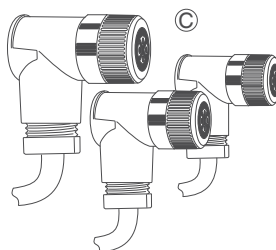

Ⓐ Order data - Positioner for direct mounting

Fieldbus	Code
Without	000
DeviceNet	DN
Profibus-DP	DP

Options	Code
Without	00
2 additional digital inputs 24 V DC not possible with Profibus DP and DeviceNet version	01

Action	Code
Single acting	1
Double acting	3

Flow rate	Code
Q = 150 l/min	01
Q = 200 l/min	02
Q = 300 l/min (only single acting)	03

Device version	Code
Positioner	SA01
Positioner and process controller	PA01

Travel length	Code
Potentiometer, 30 mm length (for linear actuators)	030
Potentiometer, 50 mm length (for linear actuators)	050
Potentiometer, 75 mm length (for linear actuators)	075
Rotary potentiometer, 90° (for quarter turn actuators)	090

Note: The required travel length depends on the max. stroke of the process valve and must be selected according to the mounting kits listed.

Order example	1436	000	Z	1	SA01	00	01	030
Type	1436							
Fieldbus (code)		000						
Accessory			Z					
Action (code)				1				
Device version (code)					SA01			
Options (code)						00		
Flow rate (code)							01	
Travel length (code)								030

B Order data - Mounting kit for linear actuators

Type	DN	Control function	Actuator size	Travel length	Footnote	Order number
695	15-25	1	1	030		1436S01Z201503000
695	15-40	2	1,2	030		1436S01Z210903000
695	15-40	3	1,2	030	1)	1436S01Z210903000
695	32-40	1	2	030		1436S01Z201103000
695	50	1	3	030		1436S01Z201803000
695	50	2	3	030		1436S01Z211503000
695	50	3	3	030	1)	1436S01Z211503000
710		1,2	0	030		1436S01Z251503000
710		1,2	1	050		1436S01Z252505000
710		1,2	2	050		1436S01Z252505000
710		1,2	3	075		1436S01Z251407500
710		3	0	030	1)	1436S01Z251503000
710		3	1	050	1)	1436S01Z252505000
710		3	2	050	1)	1436S01Z252505000
710		3	3	075	1)	1436S01Z251407500
9415		1	0	030		1436S01Z251503000
9415		1	1	050		1436S01Z252505000
9415		1	2	050		1436S01Z252505000
9415		1	3	075		1436S01Z251407500
9415		3	0	030	1)	1436S01Z251503000
9415		3	1	050	1)	1436S01Z252505000
9415		3	2	050	1)	1436S01Z252505000
9415		3	3	075	1)	1436S01Z251407500
R690	15-25	1	E	030		1436S01Z200903000
R690	15-50	2	E,F,H	030		1436S01Z210903000
R690	15-50	3	E,F,H	030	1)	1436S01Z210903000
R690	32	1	F	030		1436S01Z201503000
R690	40-50	1	H	030		1436S01Z201103000
R690	65	1	K	030		1436S01Z201803000
R690	65	2	K	030		1436S01Z211503000
R690	65	3	K	030	1)	1436S01Z211503000
R690	80-100	1	M,N	050		1436S01Z551305000
R690	80-100	2	M,N	050		1436S01Z562505000
R690	80-100	3	M,N	050	1)	1436S01Z562505000
SUPM		1	1T1	030		1436S01Z292403000

Footnote

1) For control function DA use double acting positioner (action code 3).

4) For control applications use positioner with K number 2442

© Order data - Connection kit

Fieldbus	Code
Connection kit	S02

Accessory	Code
Accessory	Z

Connections X1* and X3*, A-coded	Code
Without connector socket, with M12 protection cap	0000
M12 socket, A-coded, angle, without cable, screw terminal	00M0
M12 socket, A-coded, angle, with 5 m PUR cable, 0.34 mm ²	05M0
M12 socket, A-coded, angle, with 10 m PUR cable, 0.34 mm ²	10M0
M12 socket, B-coded, angle, can be shielded, M12 plug, B-coded, angle, can be shielded, for Profibus DP (only connection X2, B-coded DPM0 available)	DPM0

Connection X2**, B-coded	Code
Without connector socket, with M12 protection cap	0000
M12 socket, B-coded, angle, without cable, screw terminal	00M0
Y cable + 1 x M12 socket, B-coded, angle without cable, screw terminal	00Y0
Y cable + M12 socket, B-coded, angle, with 5 m PUR cable, 0.34 mm ² 5 m Sub-D connecting cable	05Y0
Y cable + M12 socket, B-coded, angle, with 10 m PUR cable, 0.34 mm ² 10 m Sub-D connecting cable	10Y0
M12 socket, A-coded, angle, can be shielded, without cable for Profibus DP (only connection X1/X3, A-coded DPM0 available)	DPM0

* X1 and X3 with Profibus DP version: B-coded

** X2 with Profibus DP version: A-coded

Order example	1436	S02	Z	00M0	00M0
Type	1436				
Fieldbus (code)		S02			
Accessory (code)			Z		
Connections X1* and X3*, A-coded (code)				00M0	
Connection X2**, B-coded (code)					00M0

© Order data - Mounting kit for quarter turn actuators

Mounting kit	Code
Mounting kit - Quarter turn actuators	PTAZ

Measuring range	Code
Angle of rotation 90°	090

NAMUR size	Code
Hole spacing 80x30, shaft height 20	01
Hole spacing 80x30, shaft height 30	02
Hole spacing 130x30, shaft height 30	03
Hole spacing 130x30, shaft height 50	04

Control air connector	Code
Without	000

Order example	1436	PTAZ	01	090	000
Type	1436				
Mounting kit (code)		PTAZ			
NAMUR size (code)			01		
Measuring range (code)				090	
Control air connector (code)					000

Order data for remote mounting

For remote mounting the following components are required which must be ordered separately:

Linear actuators		Quarter turn actuators	
Positioner GEMÜ 1436...S01 See order data - Positioner (remote mounting)	(E)	Positioner GEMÜ 1436...S01 See order data - Positioner (remote mounting)	(E)
Travel sensor GEMÜ 4232...4001 See order data - Travel sensor for linear actuators	(F)	Travel sensor GEMÜ 4231...4001 See order data - Travel sensor for quarter turn actuators	(H)
Travel sensor mounting kit GEMÜ 4232 S01 Z... See order data - Mounting kit for linear actuators	(G)	Travel sensor mounting kit GEMÜ 4231 PTAZ... See order data - Mounting kit for quarter turn actuators	(I)
Mounting bracket for wall mounting GEMÜ 1436 000 ZMP Order code - 1436 000 ZMP	-	Mounting bracket for wall mounting GEMÜ 1436 000 ZMP Order code - 1436 000 ZMP	-
Connection kit GEMÜ 1436 S02 Z... See order data - Connection kit	(C)	Connection kit GEMÜ 1436 S02 Z... See order data - Connection kit	(C)

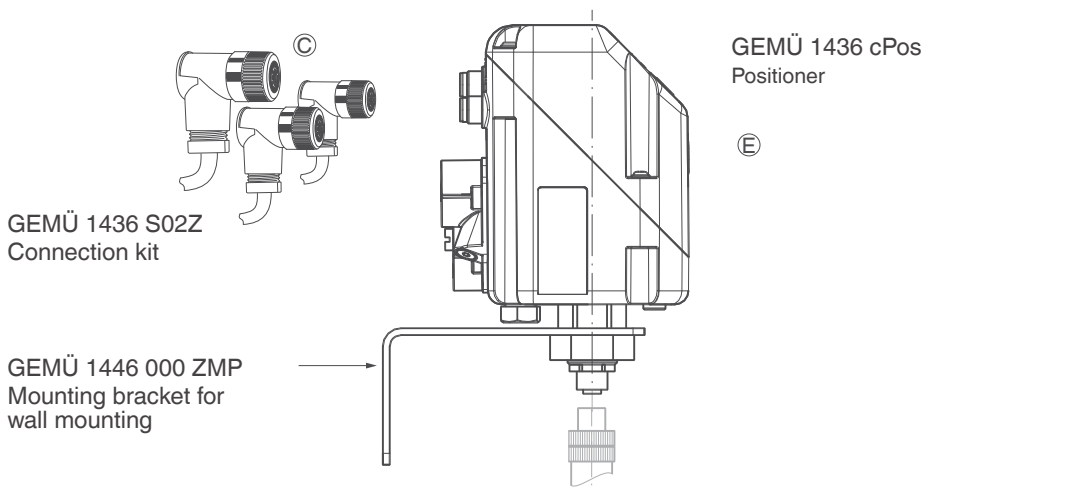

Remote mounting to linear actuator

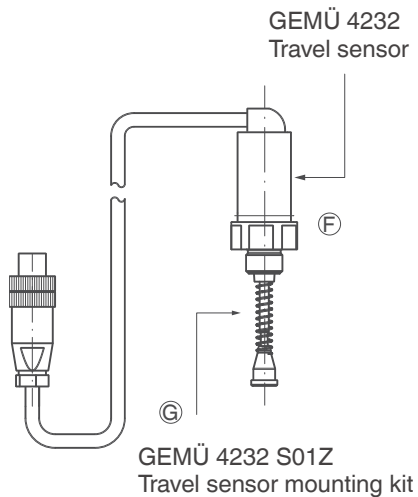

Remote mounting to quarter turn actuator

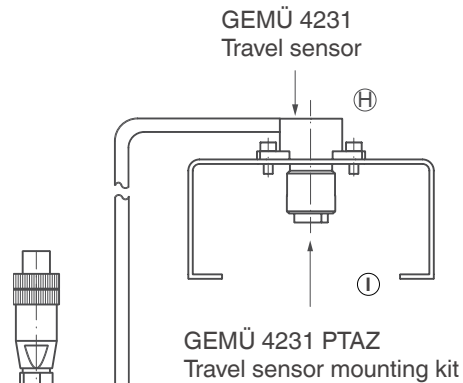

E Order data - Positioner for quarter turn actuators

Fieldbus	Code
Without	000
DeviceNet	DN
Profibus-DP	DP

Options	Code
Without	00
2 additional digital inputs 24 V DC not possible with Profibus DP and DeviceNet version	01

Action	Code
Single acting	1
Double acting	3

Flow rate	Code
Q = 150 l/min	01
Q = 200 l/min	02
Q = 300 l/min (only single acting)	03

Device version	Code
Positioner	SA01
Positioner and process controller	PA01

Travel length	Code
For external potentiometer, M 12 connector, 5-pin	S01

Order example	1436	000	Z	1	SA01	00	01	S01
Type	1436							
Fieldbus (code)		000						
Accessory			Z					
Action (code)				1				
Device version (code)					SA01			
Options (code)						00		
Flow rate (code)							01	
Travel length (code)								S01

F Order data - Travel sensor for linear actuators

Housing material	Code
PP coated	05
Aluminium, black anodized	14
PVDF coated (suitable for High Purity)	20

Cable length	Code
Length 2.0 m	02M0
Length 5.0 m	05M0
Others on request	

Travel length	Code
Potentiometer, 30 mm length	030
Potentiometer, 50 mm length	050
Potentiometer, 75 mm length	075

Cable connection	Code
M12 cable plug, straight, 5-pin, plastic	4001

Note: The required travel length depends on the max. stroke of the process valve and must be selected according to the mounting kits listed.

Order example	4232	000	Z	14	030	05M0	4001
Type	4232						
Fieldbus		000					
Accessory			Z				
Housing material (code)				14			
Travel length (code)					030		
Cable length (code)						05M0	
Cable connection (code)							4001

G Order data - Mounting kit for linear actuators

Type	DN	Control function	Actuator size	Travel length	Footnote	Order number
600	15-25	1	2	030		4232S01Z201503000
600	32-40	1	3	030		4232S01Z201103000
600	50	1	4	030		4232S01Z203003000
605		1	0	030		4232S01Z050103000
605		2	0	030	2)	4232S01Z050103000
605		3	0	030	1)	4232S01Z050103000
610		1	1	030		4232S01Z050103000
610		2	1	030	2)	4232S01Z050103000
610		3	1	030	1)	4232S01Z050103000
615		1	1	030		4232S01Z050103000
615		2	1	030	2)	4232S01Z050103000
615		3	1	030	1)	4232S01Z050103000
620		1	3/1-3/3	050		4232S01Z551305000
620		1	4A1-4A3	075		4232S01Z752607500
620		2	3/F	050	2)	4232S01Z562505000
620		2	4AF	075	2)	4232S01Z593707500
620		3	3/D	050	1)	4232S01Z562505000
620		3	4AD	075	1)	4232S01Z593707500
620	15-25	1	0	030		4232S01Z201503000
620	15-40	2	0,1	030	2)	4232S01Z210903000
620	15-40	3	0,1	030	1)	4232S01Z210903000
620	32-40	1	1	030		4232S01Z201103000
620	50	1	2	030		4232S01Z201803000
620	50	2	2	030	2)	4232S01Z211503000
620	50	3	2	030	1)	4232S01Z211503000
625		1	1	030		4232S01Z050103000
625		2	1	030	2)	4232S01Z050103000
625		3	1	030	1)	4232S01Z050103000
630		1	1	030		4232S01Z211503000
650		1	0	030		4232S01Z093903000
650		1	1,2,3,4	030		4232S01Z292403000
650		1	5,6	050		4232S01Z782505000
650		2	0TA	030	2)	4232S01Z093903000
650		2	1,2,3,4	030	2)	4232S01Z294403000
650		3	0	030	1)	4232S01Z093903000
650		3	1,2,3,4	030	1)	4232S01Z294403000
656	25-40	1		050		4232S01Z551705000
656	50-65	1		050		4232S01Z552505000
656	80-100	1		075		4232S01Z752607500
656	80-100	2		075	2)	4232S01Z593707500
658		1	1	030		4232S01Z213803000
687		1	B	030		4232S01Z211503000
687		2	B	030	2)	4232S01Z050103000
687		3	B	030	1)	4232S01Z050103000
687	15-25	1	1	030		4232S01Z201503000
687	15-40	2	1,2	030	2)	4232S01Z210903000
687	15-40	3	1,2	030	1)	4232S01Z210903000
687	32-40	1	2	030		4232S01Z201103000
687	50	1	3	030		4232S01Z201803000
687	50	2	3	030	2)	4232S01Z211503000
687	50	3	3	030	1)	4232S01Z211503000
687	65-100	1	4,5	050		4232S01Z551305000
687	65-100	2	4,5	050	2)	4232S01Z562505000
687	65-100	3	4,5	050	1)	4232S01Z562505000
688		1	1V1	030		4232S01Z200103000
688		1	2V1	050		4232S01Z575905000
695	15-25	1	1	030		4232S01Z201503000
695	15-40	2	1,2	030	2)	4232S01Z210903000
695	15-40	3	1,2	030	1)	4232S01Z210903000
695	32-40	1	2	030		4232S01Z201103000
695	50	1	3	030		4232S01Z201803000
695	50	2	3	030	2)	4232S01Z211503000
695	50	3	3	030	1)	4232S01Z211503000
710		1,2	0	030		4232S01Z251503000
710		1,2	1	050		4232S01Z252505000
710		3	0	030	1)	4232S01Z251503000
710		3	1	050	1)	4232S01Z252505000

Type	DN	Control function	Actuator size	Travel length	Footnote	Order number
710		1,2	0	030		4232S01Z251503000
710		1,2	1	050		4232S01Z252505000
710		3	0	030	1)	4232S01Z251503000
710		3	1	050	1)	4232S01Z252505000
9415		1	0	030		4232S01Z251503000
9415		1	1	050		4232S01Z252505000
9415		3	0	030	1)	4232S01Z251503000
9415		3	1	050	1)	4232S01Z252505000
C50		1,2	1,2	030		4232S01Z028003000
C50		1,2	1,2	030		4232S01Z028003000
C50		1,2	3,4	030		4232S01Z440203000
C50		1,2	3,4	030		4232S01Z440203000
C60		1	1	030		4232S01Z072703000
C60		1	1	030		4232S01Z072703000
C60		1	2,3	030		4232S01Z270203000
C60		1	2,3	030		4232S01Z270203000
C60		2	1	030	2)	4232S01Z072703000
C60		2	1	030	2)	4232S01Z072703000
C60		2	2	030	2)	4232S01Z270203000
C60		2	2	030	2)	4232S01Z270203000
C60		3	1	030	1)	4232S01Z072703000
C60		3	1	030	1)	4232S01Z072703000
C60		3	2,3	030	1)	4232S01Z270203000
C60		3	2,3	030	1)	4232S01Z270203000
R690	15-25	1	E	030		4232S01Z200903000
R690	15-50	2	E,F,H	030	2)	4232S01Z210903000
R690	15-50	3	E,F,H	030	1)	4232S01Z210903000
R690	32	1	F	030		4232S01Z201503000
R690	40-50	1	H	030		4232S01Z201103000
R690	65	1	K	030		4232S01Z201803000
R690	65	2	K	030	2)	4232S01Z211503000
R690	65	3	K	030	1)	4232S01Z211503000
R690	80-100	1	M,N	050		4232S01Z551305000
R690	80-100	2	M,N	050	2)	4232S01Z562505000
SUPM		1	1T1	030		4232S01Z292403000

Footnote

- 1) Use double acting positioner for control functions DA or DA-NO in combination with a positioner
- 2) For control function NO in combination with type 1435 also order pneumatic throttle 1435DR-Z
- 3) For control applications use positioner with K number 2443
- 4) For control applications use positioner with K number 2442

(H) Order data - Travel sensor for quarter turn actuator

Housing material	Code
PAI	XF

Travel length	Code
Potentiometer, 90°	090

Cable length	Code
Length 2.0 m	02M0
Length 5.0 m	05M0
Others on request	

Cable connection	Code
M12 cable plug, straight, 5-pin, plastic	4001

Order example	4231	000	Z	XF	090	05M0	4001
Type	4231						
Fieldbus		000					
Accessory			Z				
Housing material (code)				XF			
Travel length (code)					090		
Cable length (code)						05M0	
Cable connection (code)							4001

(I) Order data - Travel sensor mounting kit

Mounting kit	Code
Mounting kit - Quarter turn actuators	PTAZ

NAMUR size	Code
Hole spacing 80x30, shaft height 20	01
Hole spacing 80x30, shaft height 30	02
Hole spacing 130x30, shaft height 30	03
Hole spacing 130x30, shaft height 50	04

Measuring range	Code
Angle of rotation 90°	090

Control air connector	Code
Without	000

Order example	4231	PTAZ	01	090	000
Type	4231				
Mounting kit (code)		PTAZ			
NAMUR size (code)			01		
Measuring range (code)				090	
Control air connector (code)					000

23 Fail safe function

Fail safe function			
No.	Error	Outlet A1	Outlet A2
1	Power supply failure	Single acting: vented Double acting: vented	Single acting: non existent Double acting: pressurized
2	Compressed air supply failure	Single acting: vented Double acting: not defined	Single acting: non existent Double acting: closed

This fail safe function is not a substitute for specific plant safety requirements.

Adjustable safety reactions			
No.	Error	Outlet A1	Outlet A2
1	Set value < 4.0 mA (Range adjustable from 0...22 mA under I Min W)	Single acting: adjustable function Double acting: adjustable function (open, close, hold)	Single acting:- Double acting:adjustable function (open, close, hold)
2	Set value > 20.0 mA (Range adjustable from 0...22 mA under I Max W)		
3	Actual value < 4.0 mA (Range adjustable from 0...22 mA under I Min X)		
4	Actual value > 20.0 mA (Range adjustable from 0...22 mA under I Max X)		

No. 3 and 4 only available for device version code PA01

24 Application examples

24.1 GEMÜ 1436 cPos as process controller with 4-wire transmitter (GEMÜ 3021)

1436 cPos Intelligent positioner
Intelligenter Stellungsregler

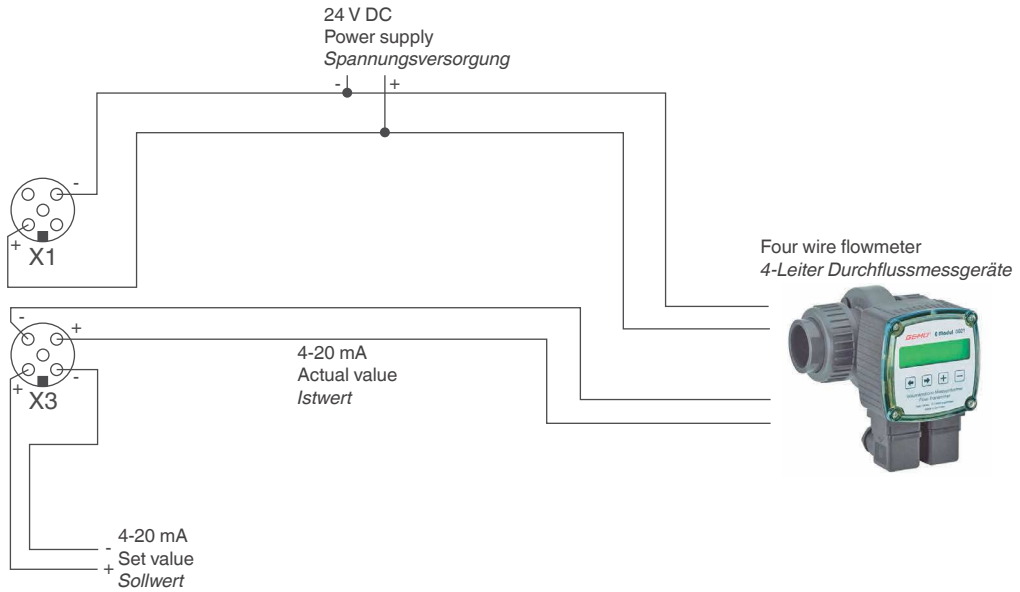

GEMÜ globe / diaphragm valve
+ GEMÜ 1436 cPos

24.2 GEMÜ 1436 cPos s process controller with 2-wire transmitter (GEMÜ 3020)

1436 cPos Intelligent positioner
Intelligenter Stellungsregler

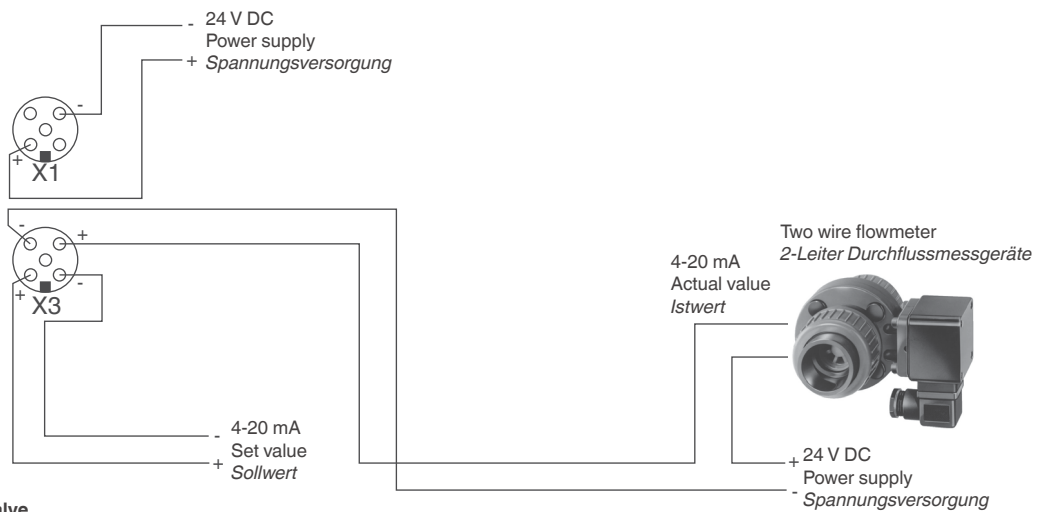

GEMÜ globe / diaphragm valve
+ GEMÜ 1436 cPos

EU Declaration of Conformity

Hereby we, **GEMÜ Gebr. Müller Apparatebau GmbH & Co. KG**
Fritz-Müller-Straße 6-8
D-74653 Ingelfingen

declare that the product listed below complies with the following directive:

- EMC Directive 2014/30/EU

Product: GEMÜ 1436



Joachim Brien
Head of Technical Department

Ingelfingen-Criesbach, September 2016

List of terms

A

Access authorisation 20
Actual value input 11
Actual value output 11
Additional air throttle for A1 10
Additional air throttle for A2 10
adjTime 17
Air missing 41
AlarmMaxK1 28, 36, 48
AlarmMaxK2 28, 36, 48
AlarmMinK1 28, 36, 48
AlarmMinK2 28, 36, 48
Application examples 62
Applikationsbeispiele 62
Automatic operation 19
AutoReturn 27, 33, 47
Avr 34

B

Bestelldaten 51
BT Name 40, 48

C

CalPointQty 27, 47
Clear Error List 26
CloseTight 27, 35, 47
Code 31
Commissioning 14
Communication 40
Configuration level 13
Configuration menu 20
Control difference 44, 45–66
Controlled variable 44
Control parameters 44
CpyParaSet 28, 37
CtrlFn 17

D

DeadBand 27, 35, 47
Decimalpoint 29, 39, 48
Default 27, 33
Delivery 5
Delivery and performance 5
Derivative action time 44
Diagnosis 41
Differential component 44
Differential equation 45
Digital Input 27, 35
Digital inputs 11
DigitalOutput 36
Disturbance variable 44
Dlight 33
DLight 33, 47
D.Refresh 27, 33, 47

E

Electrical connections 10
ErrorAction 28, 37, 48
ErrorList 32
Errors 26, 32, 47
ErrorTime 48
Exhaust air throttle for A1 10
Explanation of signs 4

F

Fail safe function 5, 61
Fehlermeldungen 41
Fieldbus 29, 40, 48
findCoefficient 17
findFnct 17
Function 5

G

goClose 17
goOpen 17

H

HelpLanguage 27, 47
HelpText 27, 47
hrs 26, 32

I

I Max W 29, 39, 48
I Max X 29, 39, 48
I Min W 29, 39, 48
I Min X 29, 39, 48
In 1 35
In 2 35
Initialisation parameters 17
Init Pilot 17
InitValve 17, 33
Init Valve ESC 17
Init Valve Man 17
Init Valve OK 17
Integral-action component 44
Integral Anteil 44
In W 27
In X 27
I w 30
I x 30
IxFilter 34
IxType 34

K

K1 Fn 28, 47
K1 Switch 11, 28, 36, 47
K2 Fn 28, 48

L

Leakage 14, 16, 41
Logout 31

M

Manipulated variable 44
MANUAL 13
Manual initialisation 14
Manuelle Initialisierung 14
Manufacturer's information 5
MaxPos 35
Mechanical mounting 7
Menu levels 13
MinPos 35
min-Pot-max 26, 30
Mode 13
Mounting 7
Mounting bracket 10

N

New Code 20, 26, 47
NO ERROR 41
Non-return valve 10

O

OnKey 33
OpenTight 35
Operating modes 19
Operation 13
Optimisation of the controller 45
Outgoing air throttle for A2 10
OutMaxPos 29, 39, 48
OutMinPos 29, 39, 48
Outputs 11

P

Parameterbedeutung 30
Parameter change 19
Pause mode 19
PinCode 40, 48
Plug X1 10
Plug X3 10
Pneumatic connections 10
Pneumatic Error 16, 41
PosCtrl 35
PosCtrlOut 26
Pos D 35
Positioner 9
Pos P 35
Pos T 35
Pot Abs 26, 30
PotDir 48
Pot wrong dir 16, 41
ProcCtrl 34
ProcCtrlMode 34
ProcCtrlOut 26
Proc-D 34
Proc-I 27, 34, 47
Proc-P 27, 34, 47
Proc-T 27, 34, 47
Proportional action factor 44, 45
Proportional band 44

R

RC 34
Reference variable 44
Relay 30
Reset 33
Reset time 45
RS232 12

S

Scaling 39
Service 20, 21, 26
SetBasics 20, 22, 27
SetCalibration 20, 24, 29, 38
SetFunction 20, 23, 27, 28
Set value input 11
Set W-free 29, 49
S/N 32
Special wiring 12
State 29, 40
Storage 4, 5
Supply voltage 11

T

TAG1 32, 47
TAG2 32, 47
Technische Daten 50
Test 13
Test mode 19
Transitory responses 46
Transport 4
Travel sensor 7

V

Valve 30
Venting connection 10

W

Warnings 26, 32, 47
W-Direction 29, 38, 48
Webserver 40
WebServer 40
W-Function 29, 38
W-Input 27, 33, 47
Working connection 10
W Pos X 26, 30
W Proc X 26, 30
Wrong function 16, 41

X

X-Direction 29, 38, 48
X-Input 27, 33, 47

Y

Y-Direction 29, 38, 48

Z

Ziegler-Nichols 45

GEMÜ®



Subject to alteration · 11/2018 · 88243865